

# TAAACSA®



**ACCESORIOS PARA CABLES SUBTERRÁNEOS**

**FICHA TÉCNICA**

 **elastimold®**



**DISTRIBUIDOR  
CONFIABLE**

[taacsa.com](http://taacsa.com)

# Elastimold<sup>®</sup> underground cable accessories

## Overview

Elastimold<sup>®</sup> separable connectors, cable joints, cable terminators and other cable accessory products have been designed and tested per applicable portions of IEEE, ANSI and other industry standards including:

- IEEE 386 standard for separable connectors
- IEEE 404 standard for cable joints and splices
- IEEE 48 standard for cable terminations
- IEEE 592 standard for exposed semiconducting shields
- ANSI C119.4 standard for copper and aluminum conductor connectors
- AEIC CS8 standards for XLP and EPR insulated cables
- ICEA S-94-649-2004 and S-97-682-2000 standard for cables rated 5,000 – 46,000 V

Cable joints and terminations ratings  
Refer to the pages listed below for rating information:

- PCJ<sup>™</sup> cable joints, page 59
- Cable terminations, page 64

Separable connector ratings

The following chart shows voltage and current ratings that apply to all separable connectors, including 200 A loadbreak, 200 A deadbreak and 600/900 A series deadbreak products. The next chart shows switching and fault close ratings, which only apply to 200 A loadbreak connectors.

### Voltage and current ratings

	15 kV class ratings	25 kV class ratings	35 kV class ratings
Operating voltage maximum line-to-ground (kV) (see application info note 1)	8.3	15.2	21.1
BIL impulse withstand 1.2 x 50 microsecond wave (kV)	95	125	150
Withstand voltage AC one minute	34	40	50
DC 15 minute (kV)	53	78	103
Corona extinction level @ 3pc sensitivity (kV)	11	19	26
200 A products Continuous current: Symmetrical momentary current:	–	–	200 A 10 kA sym, 10 cycle duration*
600 Series products Continuous current: Symmetrical momentary current:	–	–	600 and 900 A 25 kA sym, 10 cycle duration*

\* Designed for 90 °C maximum continuous operating temperature.



Application information:

1. Loadbreak connectors are designed and rated for use on grounded Wye systems. For application on ungrounded Wye or delta systems, the next higher voltage class product is recommended.

Examples:

- 5 kV ungrounded: use 15 kV class products;
- 15 kV ungrounded: use 25 kV class products;
- 25 kV ungrounded: use 35 kV class products.

2. Products are designed and constructed for all applications, including padmount, subsurface, vault, indoor, outdoor, direct sunlight, direct buried and continuously submerged in water.

3. Products are designed and rated for ambient temperatures of -40 °C to 65 °C. It is recommended that loadbreak connectors be hotstick operated at -20 °C to 65 °C ambient temperature range and at altitudes not exceeding 6000 feet.

Switching and fault close ratings

	Loadmake/loadbreak switching	Fault close
15 kV class ratings	<p>1Ø and 3Ø circuits 8.3 kV line to ground, 14.4 kV max. across open contacts</p> <hr/> <p>10 loadmake/break operations at 200 A max. with 70 to 80% lagging power factor</p>	<p>1 fault close operation at 8.3 kV or 14.4 kV; 10,000 A RMS sym;</p> <p>10 cycles (0.17 sec.) 1.3 max. asym factor applies to new or used mating parts (up to maximum designated switching operations)</p>
25 kV class ratings	<p>1Ø and 3Ø circuits 15.2 kV line to ground, 26.3 kV max. across open contacts</p> <hr/> <p>10 loadmake/break operations at 200 A max. with 70 to 80% lagging power factor</p>	<p>1 fault close operation at 15.2 kV or 26.3 kV; 10,000 A RMS sym;</p> <p>10 cycles (0.17 sec.) 1.3 max. asym factor applies to new or used mating parts (up to maximum designated switching operations.)</p>
35 kV class ratings	<p>1Ø and 3Ø circuits 21.1 kV line to ground, 36.6 kV max. across open contacts.</p> <hr/> <p>10 loadmake/break operations at 200 A max. with 70 to 80% lagging power factor.</p>	<p>1 fault close operation at 21.1 kV or 36.6 kV; 10,000 A RMS sym;</p> <p>10 cycles (0.17 sec.) 1.3 max. asym factor applies to new or used mating parts (up to maximum designated switching operations)</p>







\* Designed for 90 °C maximum continuous operating temperature.

## Elastimold<sup>®</sup> underground cable accessories Overview

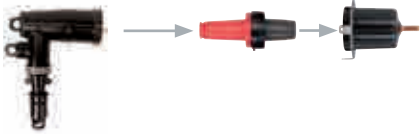
Standard interfaces for separable connectors, components and equipment bushing  
The latest revision of IEEE standard 386 defines the specific interface dimensions to which 200 A and 600 series elbows, inserts, junctions, equipment bushings and any mating components must

conform to ensure interchangeability.  
The table below provides information concerning the types of interfaces supplied by Elastimold products for various applications and is useful to ensure proper matching of components.

Types of interfaces supplied by Elastimold

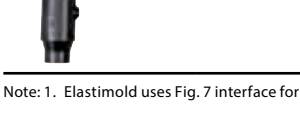
	Bushing interface	Voltage class (kV)	Interface description	Standard no. Figure no.
	200 A deepwell equipment bushing	15, 25 and 35	200 A bushing well interface 8.3 kV, 15.2 kV and 21.1 kV	IEEE 386 Fig. 3
	200 A loadbreak insert	15	200 A loadbreak 8.3 kV and 8.3 kV/14.4 kV	IEEE 386 Fig. 5
	200 A loadbreak insert	25	200 A loadbreak 15.2 kV and 15.2 kV/26.3 kV	IEEE 386 Fig. 7, Note 1
	200 A loadbreak insert	35	200 A loadbreak interface no. 2 21.1 kV and 21.1 kV/36.3 kV	IEEE 386 Fig. 7, Note 1
	200 A deadbreak insert	15 and 25	200 A deadbreak 8.3 kV and 15.2 kV	IEEE 386 Fig. 4
	600 Series equipment bushing	15 and 25	600 A deadbreak interface no. 1 8.3 kV and 15.2 kV	IEEE 386 Fig.11
	600 Series equipment bushing	35	600 A deadbreak interface no. 1 21.1 kV	IEEE 386 Fig.13

Note: 1. Elastimold uses Fig. 7 interface for both 25 and 35 kV applications.

## 200 A loadbreak elbows Connectors and accessories

200 A loadbreak connectors and accessories provide a convenient method to connect/disconnect cable and equipment on power distribution systems. Loadbreak elbows include provisions for energized operation using standard hotstick tools, allowing loadmake/break operation and a visible disconnect. Components can be isolated with insulated caps, plugs and parking bushings.

Optional accessories allow system grounding, testing, bypass, surge protection and current limiting fusing. Additional connecting points and taps can be provided by use of junctions or feed-thrus.

### Elastimold 200 A loadbreak elbow (15 kV and 25 kV)

#### Switching made easier

The Elastimold 200 A loadbreak elbow (15 kV and 25 kV series) incorporates decades of innovative design and manufacturing experience that directly addresses end users' needs. The design incorporates safety performance features, increases range flexibility and improves life cycle cost reduction. In addition, Elastimold 200-amp loadbreak elbow has Rural Utilities Service (RUS) acceptance from the U.S. Department of Agriculture (USDA), which authorizes its use in rural infrastructure construction and improvements.

#### Enhance safety

- Rigid probe support to ensure proper switching
- No stick interface when used with Elastimold bushings (NEETRAC\* tested)
- Robust stainless-steel pulling eye
- Dual grounding eye positions

#### Increase flexibility

- Additional sizes available
- Improved wider cable ranges
- Easy order system
- Optional integral jacket seal

#### Improve life cycle cost reduction

- Optimized for switching operations
- Lifetime ease of operation and non-stick when used with Elastimold bushings
- Seal system for traditional and jacket seal options

#### IEEE 386 compliant

ANSI certification

Rural Utilities Service (RUS) acceptance

\* National Electric Energy Testing, Research and Applications Center

## 200 A loadbreak elbows

### Overview

—  
01 15/25 kV class  
—  
02 15/25 kV class

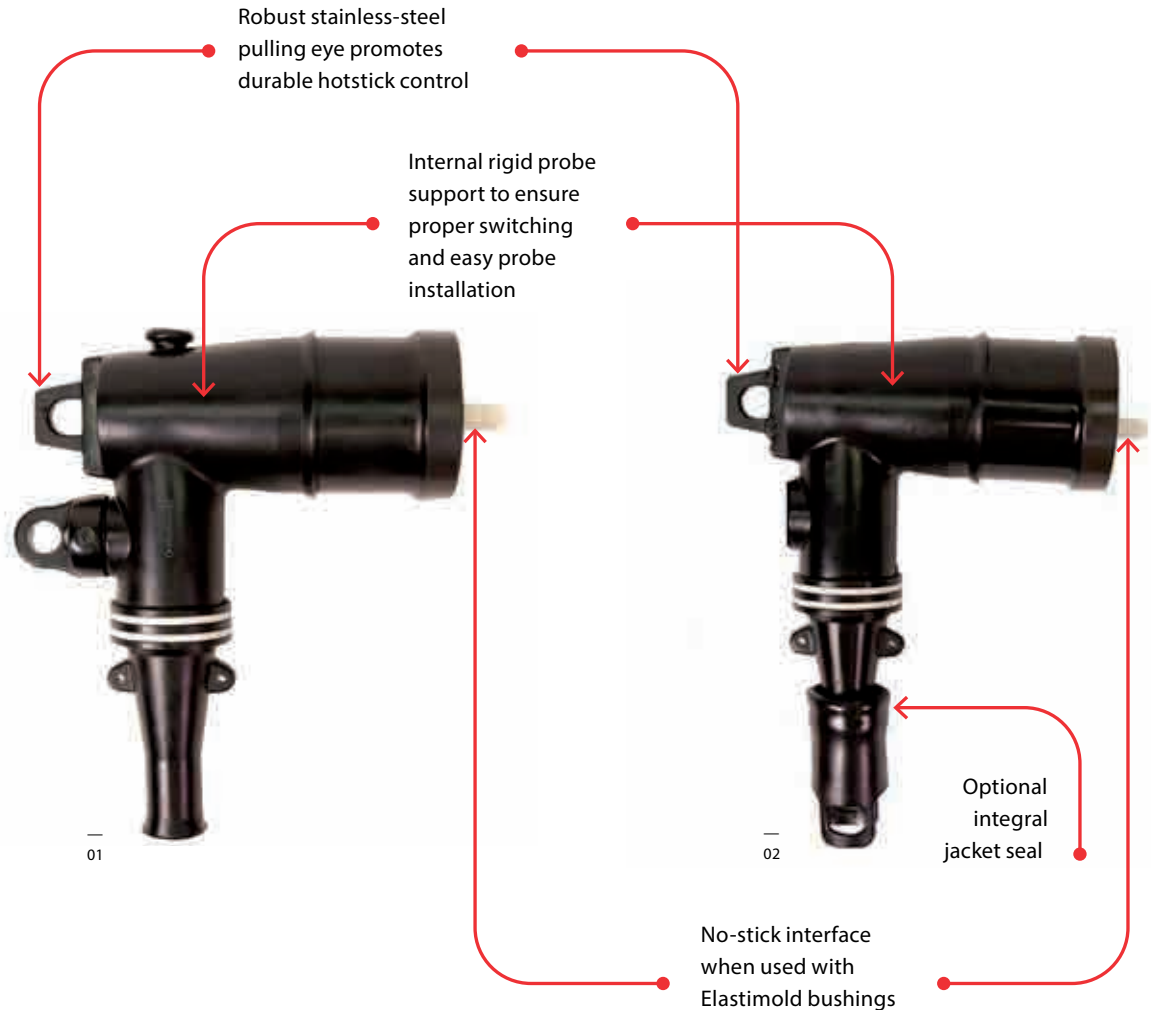

### Ratings overview

See pages 4–5 for complete information, including switching and fault close ratings.

#### Current ratings

- 200 A continuous
- 10 kA sym. 10 cycles

#### Voltage ratings

- 15 kV class
- 8.3 kV phase-to-ground
- 14.4 kV phase-to-phase
- 95 kV BIL
- 34 kV AC withstand
- 53 kV DC withstand
- 11 kV corona extinction

#### 25 kV class

- 15.2 kV phase-to-ground
- 26.3 kV phase-to-phase
- 125 kV BIL
- 40 kV AC withstand
- 78 kV DC withstand
- 19 kV corona extinction

#### 35 kV class

- 21.1 kV phase-to-ground
- 36.6 kV phase-to-phase
- 150 kV BIL
- 50 kV AC withstand
- 103 kV DC withstand
- 26 kV corona extinction

## 200 A loadbreak separable connectors Components

Cable to equipment connections  
ABB offers the complete package of underground cable accessories – everything you need to connect, ground, splice, terminate and protect underground

cable from 5 kV to 138 kV – along with solid dielectric switchgear in compact, modular designs that fit easily into tight vaults.

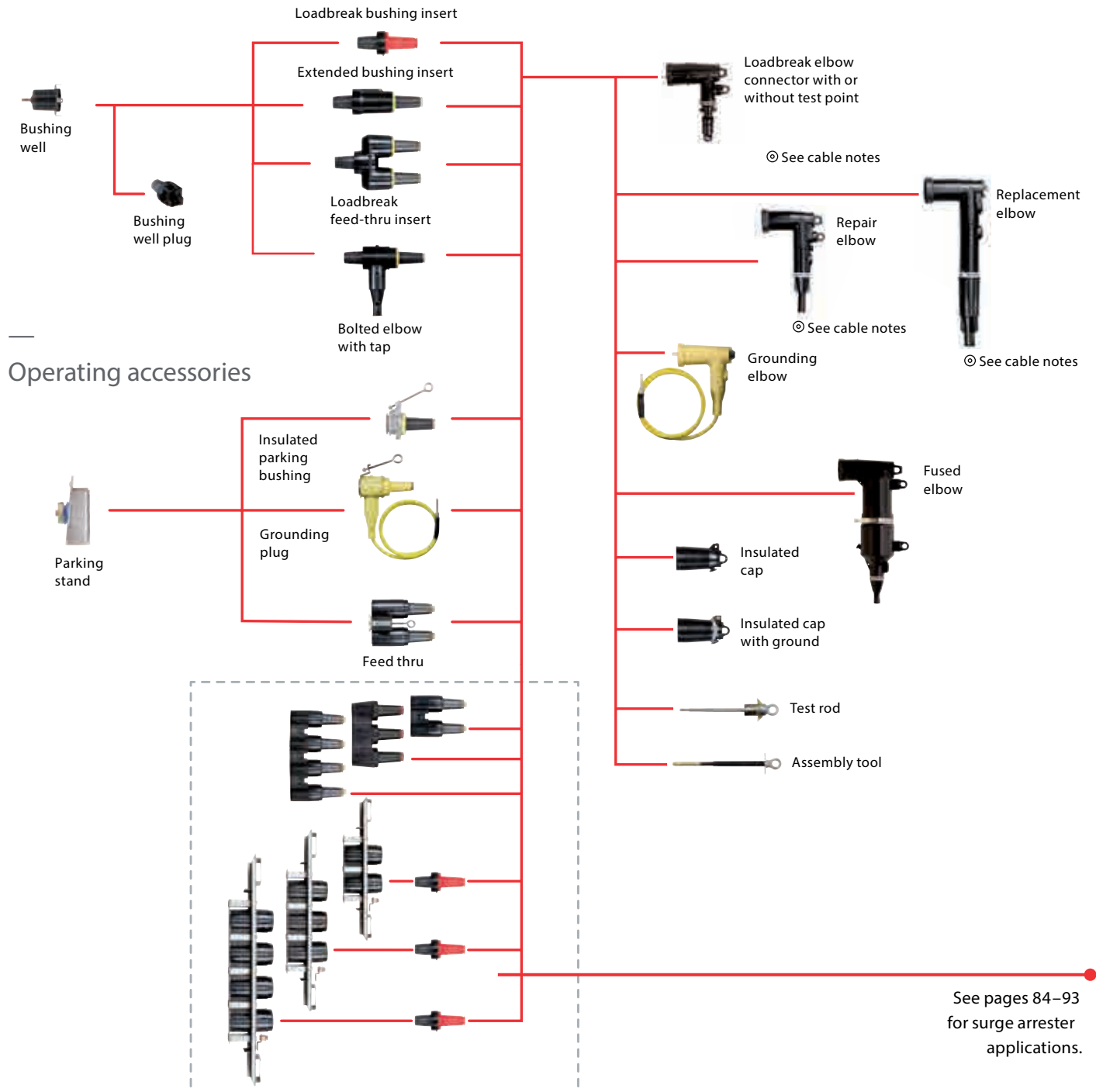

## 200 A loadbreak separable connectors

### Loadbreak elbows

Image (not to scale)	Description	Voltage class (kV)	Cat. no.	Notes
	Elbow connector without test point	15	161LR-W5X Use tables W1 and X1	N2, 3, 4, 5
		25	261LR-W5X Use tables W1 and X1	N2, 3, 4, 5
		35	375LR-W5X Use tables W3 and X2	N2, 3, 5
	Elbow connector with test point	15	162LR-W5X Use tables W1 and X1	N2, 3, 4, 5, 23
		25	262LR-W5X Use tables W1 and X1	N2, 3, 4, 5, 23
		35	376LR-W5X Use tables W3 and X2	N2, 3, 5, 23
	Jacket seal elbow connector without test point	15	161LRJS-W5X Use tables W1 and X1	N2, 19
		25	261LRJS-W5X Use tables W1 and X1	N2, 19
	Jacket seal elbow connector with test point	15	162LRJS-W5X Use tables W1 and X1	N2, 19, 23
		25	262LRJS-W5X Use tables W1 and X1	N2, 19, 23
	Repair elbow connector	15	167ELR-W5X Use tables W5 and X1	N5, 10, 18
		25	273ELR-W5X Use tables W5 and X1	N5, 10, 18
	Repair elbow connector with test point	15	168ELR-W5X Use tables W5 and X1	N5, 10, 18, 23
		25	274ELR-W5X Use tables W5 and X1	N5, 10, 18, 23
	Replacement elbow	15	167RLR-W5X Use tables W4 and X1	N5, 11, 13
		25	273RLR-W5X Use tables W2 and X1	N5, 11, 13
	Replacement elbow with test point	15	168RLR-W5X Use tables W4 and X1	N5, 11, 13, 23
		25	274RLR-W5X Use tables W2 and X1	N5, 11, 13, 23
	Direct test elbow connector	15	161DLR-W5X Use tables W1 and X1	N2, 5, 21
		25	261DLR-W5X Use tables W1 and X1	N2, 5, 21
	Direct test repair elbow connector	15	167DELR-W5X Use tables W5 and X1	N5, 10, 18, 21
		25	273DELR-W5X Use tables W5 and X1	N5, 10, 18, 21
	Direct test repair elbow connector with test point	15	168DELR-W5X Use tables W5 and X1	N5, 10, 18, 21, 23
		25	274DELR-W5X Use tables W5 and X1	N5, 10, 18, 21, 2

N1. Copper lug for use on COPPER CONDUCTOR ONLY.

N2. W5X indicates that the catalog number includes 02500X long bi-metal compression lug as standard. For an all-copper lug, replace W5X with W2X in Table X1 to specify the all-copper 02702X lug.

N3. Also available as housing only. Specify: 161BLR-W; 261BLR-W; 375BLR-W; 162BLR-W; 262BLR-W; 376BLR-W.

N4. Also available as elbow with insert combination. Specify: 161A4-WX; 261A4-WX; 162A4-WX; 262A4-WX.

N5. Also available with 200ECS jacket seal included. Add - "S" suffix to catalog number (highly recommended).

N10. Repair elbow has extended length contact and elbow housing resulting in a net gain of 3 1/4" in length.

N11. Replacement elbow has extended-length contact and elbow housing resulting in a net gain of 8 7/8" in length.

N13. Includes long bi-metal contact 00400X.

N18. Includes 02509X long bi-metal contact.

N19. Includes built-in jacket seal. Also available as housing only – specify: 161BLRJS-W, 162BLRJS-W, 261BLRJS-W or 262LRJS-W. Also available as elbow with insert combination – specify: 161JSA4-W5X, 162JSA4-W5X, 261JSA4-W5X or 262JSA4-W5X.

N21. Direct test connectors, along with a 200TC-X series meter adapter, a properly rated voltage meter and hot-line stick provide a means for direct conductor voltage testing.

N23. Test point cap catalog number 156-7

Refer to the W and X tables on pages 80–81 for sizing to cable insulation diameter and conductor size. For cable shield adapters and jacket seals, see pages 70–71.



## 200 A loadbreak separable connectors

### Loadbreak bushings





















Image (not to scale)	Description	Voltage class (kV)	Cat. no.	Notes
	Grounding plug (1/0 AWG x 6' ground lead)	15	161GP	-
		25	272GP	-
	Grounding elbow (1/0 AWG x 6' ground lead)	15	160GLR	N12
		25/35	370GLR	N12
	Feed-thru	15	164FT	N6, N18
		25	274FT	N6, N18
		35	371FT	N6, N18
		35	373FT	N6, N18
	Feed-thru vertical	15	164FTV	-
		25	274FTV	-
		35	373FTV	-
	Adjustable bracket 2-point feed-thru	15	164FT2-AB	N22
		25	274FT2-AB	N22
		35	373FT2-AB	N22
	Adjustable bracket 3-point feed-thru	15	164FT3-AB	N22
		25	274FT3-AB	N22
		35	373FT3-AB	N22
	Adjustable bracket 4-point feed-thru	15	164FT4-AB	N22
		25	274FT4-AB	N22
		35	373FT4-AB	N22
	Feed-thru well	15/25	K1601WFT	-
	Feed-thru well vertical	15/25	K1601WFTV	-
	Insulated parking bushing	15	161SOP	N20
		25	272SOP	N20
		35	372SOP	N20
	Insulated parking bushing	15	164SOP	N22
		25	274SOP	N22
	Assembly tool	All	200AT	N8
	Bushing well plug	15/25	276BWP	-
		35	M276BWP	-
	Test rod	All	370TR	-
	Bolted elbow with tap	15	167LRT-W5X Use tables W4 and X1	N17
	Bushing insert	15	1601A4	N4, 8
		25	2701A4	N4, 8
		35	3701A4	N6, 20
		35	3701A3	20

Image (not to scale)	Description	Voltage class (kV)	Cat. no.	Notes
	Extended bushing insert	15	1601EA4	N8
		25	2701EA4	N8
	Feed-thru insert	15	1602A3R	N16
		25	2702A1	N16
		35	3702A1	N6, 16
	Insulated cap	15	160DR	N9
	Insulated cap with ground	15	160DRG	N9
		15	167DRG	N7, 9
		25	273DRG	N7, 9
		35	375DRG	N7, 9
	Insulated cap with ground and test point	15	168DRG	N7
		25	274DRG	N7
		35	376DRG	N7

N4. Also available as elbow with insert combination. Specify: 161A4-WX; 261A4-WX; 162A4-WX; 262A4-WX.

N6. Rated for single-phase applications only.

N7. Equipped with insulated cuff.

N8. Includes internal torquing feature using 200AT assembly tool.

N9. Also available without probe. Specify "A" suffix - Example: 273DRGA.

N12. Rated for 25 kV thru 35 kV applications.

N16. Fully rotatable for 360° positioning. Includes bail assembly to secure feed-thru insert to bushing well.

N17. Includes 02800X bi-metal contact.

N18. Includes 02509X long bi-metal contact.

N20. Includes a black vent ring.

N22. With stainless steel bracket.

Refer to the W and X tables on pages 80–81 for sizing to cable insulation diameter and conductor size. For cable shield adapters and jacket seals, see pages 70–71.

## 200 A loadbreak separable connectors

### Connectors and accessories

#### Connectors and accessories

Image (not to scale)	Description	Voltage class (kV)	Cat. no.	Notes
	Contacts:	All	Use Table X1	-
	LR long bi-metal		02500X	
	ELR bi-metal	15/25	02509X	N1
	LR copper	All	02702X	N2
	LRT contact	15	02800X	-
	RLR contact	15/25	00400X	N3
	Elbow probe	15	166LRF	-
		35	375LRF	-
	Elbow cable entrance insulating plug	All	10EP-W Use Table W6	-
	Cable size adapter	15	160CA-W Use Table W6 EB-FA Only	N4
	Direct voltage test meter adapter for: HD electric meters	All	200TC-1	N14
	Ross meters	-	200TC-2	N14
	Chance meters	-	200TC-4	N14
	2-Way well junction with stainless steel bracket	15/25	K1601WJ2	N6
	2-Way well junction with "U" straps	15/25	K1601WJ2-5	N5, 6, 11
	3-Way well junction with stainless steel bracket	15/25	K1601WJ3	N6
	3-Way well junction with "U" straps	15/25	K1601WJ3-5	N5, 6, 12
	4-Way well junction with stainless steel bracket	15/25	K1601WJ4	N6
	4-Way well junction with "U" straps	15/25	K1601WJ4-5	N5, 6, 13
	2-Point junction with stainless steel bracket	15	164J2	N7
		25	274J2	N7
		35	373J2	N7
	2-Point junction with "U" straps	15	164J2-5	-
		25	274J2-5	N5, 8 N5, 11
	3-Point junction with stainless steel bracket	15	164J3	N7
		25	274J3	N7
		35	373J3	N7
	3-Point junction with "U" straps	15	164J3-5	N5, 9
		25	274J3-5	N5, 12
	4-Point junction with stainless steel bracket	15	164J4	N7
		25	274J4	N7
		35	373J4	N7
	4-Point junction with "U" straps	15	164J4-5	N5, 10
		25	274J4-5	N5, 13
		35	373J4-5	N5, 13

N1. Repair elbow has extended-length contact and elbow housing resulting in a net gain of 3 1/4" in length.

N2. Copper lug for use on COPPER CONDUCTOR ONLY.

N3. Replacement elbow has extended-length contact and elbow housing resulting in a net gain of 8 7/8" in length.

N4. 160CA cable size adapter can only be used with elbow catalog numbers 165LR/166LR C, H or CC size only.

N5. Also available as rubber only, without straps.

Specify suffix "-4" in place of "-5" in the catalog number.

N6. Supplied with replaceable stud. Replacement stud available separately. Specify 1000-150.

N7. Hardware packages, consisting of brackets and straps only, may be ordered separately by specifying "-6" in the catalog number. Example 164J4-6.

N8. Hardware package, consists of "U" straps and back plate only, may be ordered separately by specifying 1601US-J2.

N9. Hardware package, consists of "U" straps and back plate only, may be ordered separately by specifying 1601US-J3.

N10. Hardware package, consists of "U" straps and back plate only, may be ordered separately by specifying 1601US-J4.

N11. Hardware package, consists of "U" straps and back plate only, may be ordered separately by specifying 271-68.

N12. Hardware package, consists of "U" straps and back plate only, may be ordered separately by specifying 271-61.

N13. Hardware package, consists of "U" straps and back plate only, may be ordered separately by specifying 271-70.

N14. For use with direct test connectors.

Refer to the W and X tables on pages 80-81 for sizing to cable insulation diameter and conductor size. For cable shield adapters and jacket seals, see pages 70-71.

## Ordering information

The following diagram shows how to construct a catalog number for a 200-amp loadbreak elbow:

Indicates field that must be filled in to complete the catalog number.

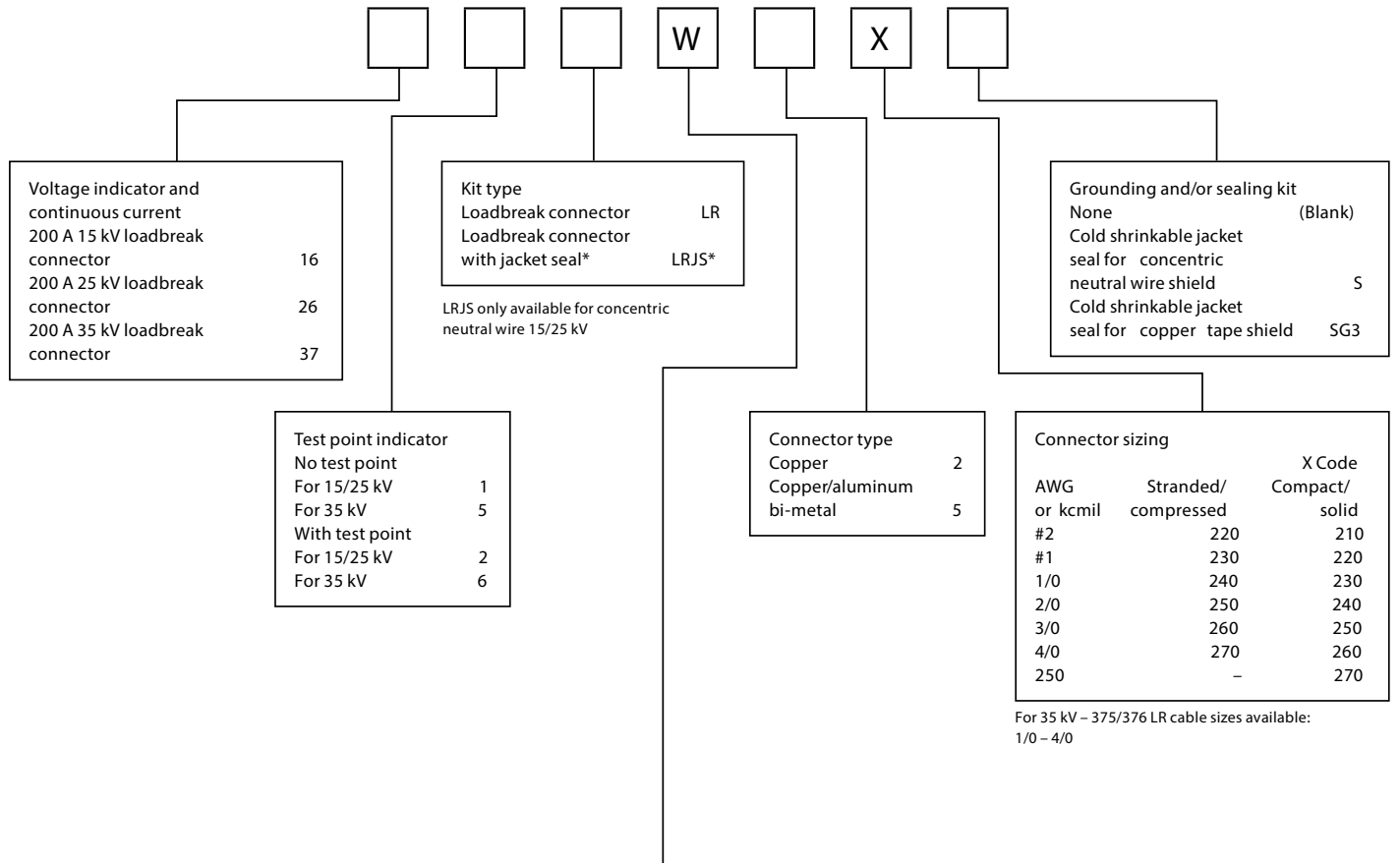

For 35 kV – 375/376 LR cable sizes available: 1/0 – 4/0

Table W1 – Elbow sizing 15/25 kV

Cable insulation diameter range				
Cable insulation diameter in in.		Cable insulation diameter in mm		Symbol for W
Min.	Max.	Min.	Max.	
0.575	0.740	14.6	18.7	A
0.635	0.905	16.1	22.9	B
0.805	1.060	20.4	26.9	C
0.890	1.220	22.6	30.9	D
1.090	1.310	27.6	33.2	E

Table W3 – Elbow sizing 35 kV

Cable insulation diameter range				
Cable insulation diameter in in.		Cable insulation diameter in mm		Symbol for W
Min.	Max.	Min.	Max.	
0.850	1.050	21.5	26.6	H
0.980	1.180	24.8	29.9	J
1.090	1.310	27.6	33.2	K
1.235	1.465	31.3	37.2	L

---

## 200 A deadbreak separable connectors

### Connectors and accessories

200 A deadbreak connectors and accessories provide a quick-disconnect feature for cable and equipment connections on power distribution systems.

All deadbreak connectors must be de-energized before operating and must be mechanically secured with bails when connected. Components can be isolated with insulated caps, plugs and parking bushings.

All deadbreak elbows are equipped with test points as standard. Optional accessories allow system grounding, bypass and lightning surge protection. Additional connecting points and taps can be provided by use of junctions or feed-thrus.

#### Ratings overview

See pages 4–5 for complete information.

#### Current ratings

- 200 A continuous
- 10 kA sym. 10 cycles

#### Voltage ratings

- 15 kV class
  - 8.3 kV phase-to-ground
  - 14.4 kV phase-to-phase
  - 95 kV BIL
  - 34 kV AC withstand
  - 53 kV DC withstand
  - 11 kV corona extinction

#### 25 kV class

- 15.2 kV phase-to-ground
- 26.3 kV phase-to-phase
- 125 kV BIL
- 40 kV AC withstand
- 78 kV DC withstand
- 19 kV corona extinction

## 200 A deadbreak separable connector components

### Cable to equipment

### Operating accessories



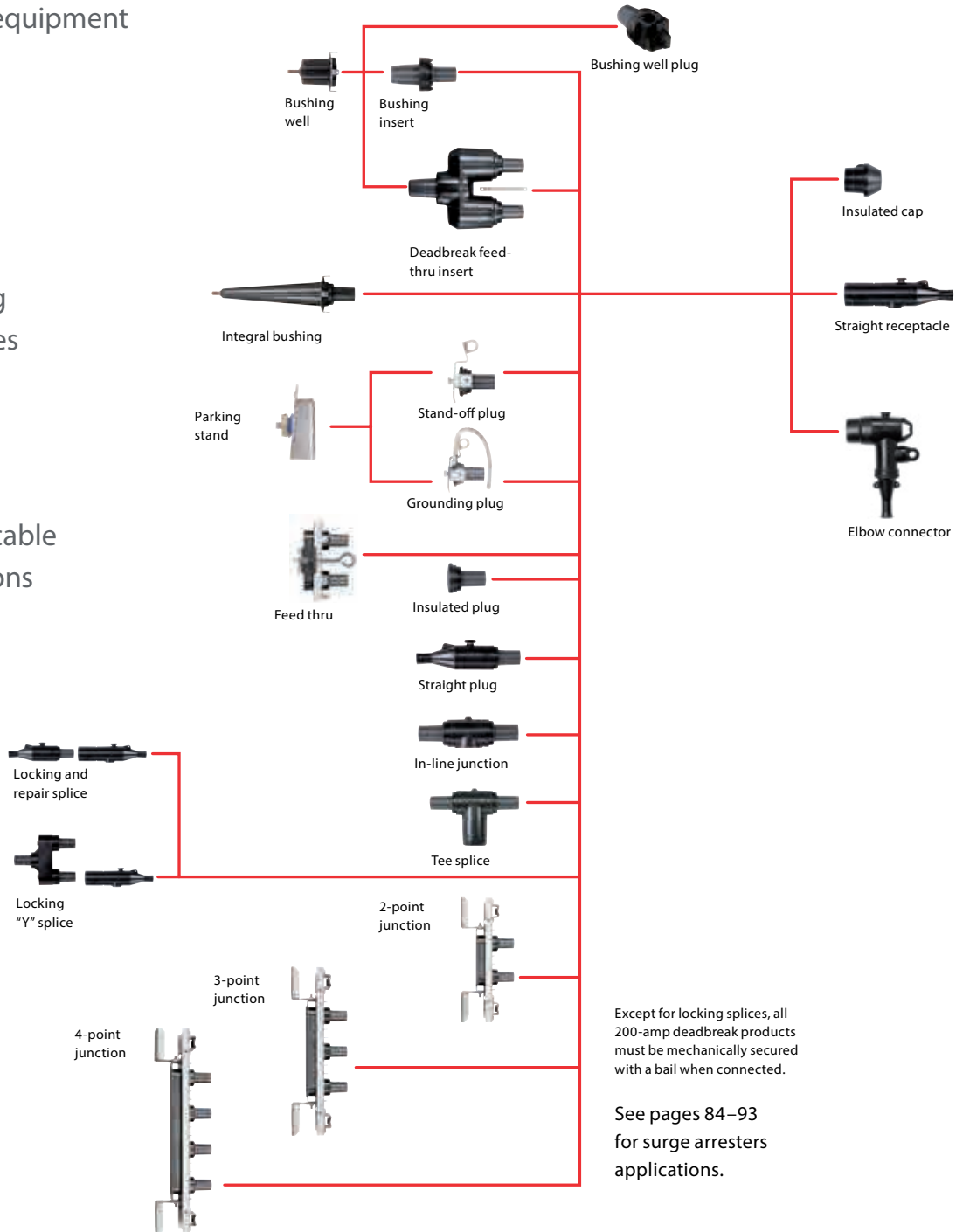













### Cable to cable connections



## 200 A deadbreak separable connectors

### Connectors and accessories

#### 200 A deadbreak separable connectors

Image (not to scale)	Description	Voltage class (kV)	Cat. no.	Notes
	Elbow connector with test point	15/25	252LR-W0X Use tables W16 and X1	N1, 2
	Jacket seal elbow connector with test point	15/25	252LRJS-W5X Use tables W16 and X1	N2, 19
	Bail assembly for 156LR elbow	15/25	150BA	–
	Bushing insert	15/25	K1501A1	N3
	Feed-thru insert	15/25	K1502A1	N3, 4
	Insulated plug	15/25	K150DP	N3
	Insulated cap	15/25	K150DR	N3
	Insulated parking bushing	15/25	K151SOP	N3
	Grounding plug	15/25	151GP	N3
	Feed-thru	15/25	K1501FT	N3, 6
	2-point junction	15/25	K1501J2-U8	N3, 6
	3-point junction	15/25	K1501J3-U8	N3, 6
	4-point junction	15/25	K1501J4-U8	N3, 6
	Elbow probe	15/25	156LRF DP 0438609	–
	Straight receptacle	15/25	K151SR-W0X Use tables W1 and X1	N3, 12, 13, 17, 18
	Straight plug	15/25	K151SP-W0X Use tables W1 and X1	N3, 12, 13, 19

N1. Includes bail assembly.

N2. W5X indicates that the catalog number includes a 02500X bi-metal compression lug, which is rated for either aluminum or copper conductor, as standard. For an all-copper lug, replace W5X with W2X. Use Table X1 to specify the all-copper 02702X lug.

N3. Bails are required but not included. Order separately. Consult factory for bails not listed for a specific application.

N4. Fully rotatable for 360° positioning. Includes bail assembly to secure feed-thru insert to bushing well. Elbows bail assemblies are required but not included with the feed-thru insert.

N6. Center-to-center spacing equals 4 inches.

N12. Also available as housing only. Specify K151BSP-W or K151BSR-W.

N13. Also available in EB-FA sizes per Table W6 by using 160CA cable adapter with C size plugs and receptacles.

N17. Straight receptacles are also available with test point.

Specify K152SR-W0X catalog number.













N18. W0X indicates that the catalog number includes a 01500X universal aluminum compression lug, which is rated for either aluminum or copper, as standard. For an all-copper lug, replace W0X with W2X in Table X1 to specify the all-copper 01502X lug.

N19. W0X indicates that the catalog number includes a 01600X universal aluminum compression lug, which is rated for either aluminum or copper, as standard. For an all-copper lug, replace W0X with W2X in Table X1 to specify the all-copper 01602X lug.

N22. Direct test connectors, along with a 200TC-X series meter adapter, a properly rated voltage meter and hot-line stick provides a means for direct conductor voltage testing. See page 12 for meter adapters.

Refer to the W and X tables on pages 80–81 for sizing to cable insulation diameter and conductor size. For cable shield adapters and jacket seals, see pages 70–71.

## 200 A deadbreak connectors and accessories

Image (not to scale)	Description	Voltage class (kV)	Cat. no.	Notes
	Tee splice	15/25	K150T	N3
	In-line junction	15/25	K150S	N3
	Locking splice/ repair splice	15/25	K151LS-W0X Use tables W1 and X1	N8, 9, 13, 15, 16, 17, 20, 23
	Locking "Y" splice	15/25	K151LY-W0X Use tables W1 and X1	N8, 9, 13, 15, 17, 21
	Bail	15/25	150TB1	N5
	Bail	15/25	150TB2	N5
	Bail	15/25	150TB3	N5
	Bail	15/25	150TB4	N5
	Bail	15/25	150TB5	N5
	Bail	15/25	150TB6	N5
	Contacts: long bi-metal copper	15/25 15/25	02500X 02702X	N7
	Elbow cable entrance insulating plug	15/25	10EP-W Use table W6	N10
	Cable entrance insulating plug	15/25	152EA-W Use table W6	N11
	Cable size adapter	15/25	160CA-W Use table W6 EB-FA only	N14

N3. Bails are required but not included. Order separately. Consult factory for bails not listed for a specific application.

N5. Refer to factory for application details.

N7. Copper lug for copper cable only.

N8. To order cable legs for different cable sizes, list each leg size "W" and "X". Example: K151LY-A1240-A1240-B1220. See Tables W1 and X1 for sizes.

N9. To order locking contacts for K151LS and K151LY, order 01401X (Al) or 01402X (Cu) for plug contact. Order 01301X (Al) or 01302X (Cu) for receptacle. See Table X1 for sizes.

N10. For use with 156LR elbows.

N11. For use with K151SR, K151SP, K151LS, K151LY receptacles, plugs and splices.

N13. Also available in EB-FA sizes per Table W6 by using 160CA cable adapter with C size plugs and receptacles.

N14. 160CA cable adapter can only be used with C size plugs and receptacles.

N15. Bails are not required for locking splices.

N16. When used as a repair splice, the assembled length allows 4" for cable replacement/repair.

N17. Straight receptacles are also available with test point. Specify K152SR-W0X catalog number.

N20. W0X indicates that the catalog number includes a 01400X universal aluminum compression lug, which is rated for either aluminum or copper, as standard. For an all-copper lug, replace W0X with W2X in Table X1 to specify the all-copper 01402X lug.

N21. W0X indicates that the catalog number includes a 01300X universal aluminum compression lug, which is rated for either aluminum or copper, as standard. For an all-copper lug, replace W0X with W2X in Table X1 to specify the all-copper 01302X lug.

N23. Gains approximately 4" of repair length.

Refer to the W and X tables on pages 80–81 for sizing to cable insulation diameter and conductor size. For cable shield adapters and jacket seals, see pages 70–71.

## 200 A deadbreak separable connectors 15/25 kV deadbreak elbow connectors ordering information

The following diagram shows how to construct a catalog number for a 200 A deadbreak elbow connector:

Indicates field that must be filled in to complete the catalog number.

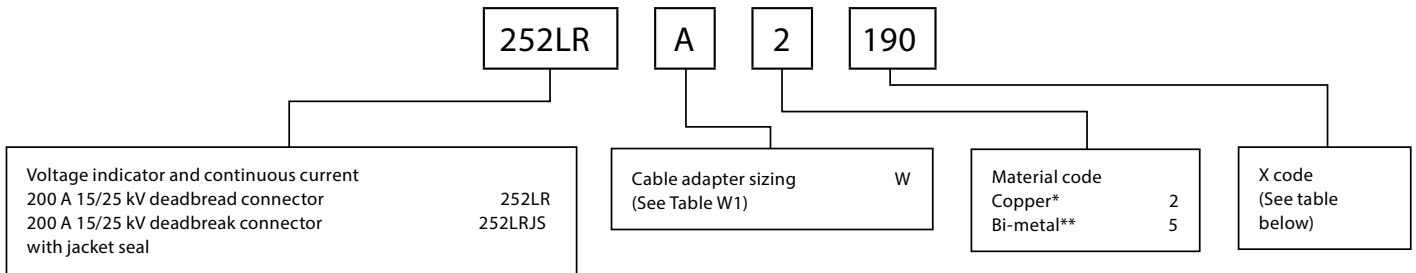

Table W1 – Cable insulation dia. range

Inches		mm		Symbol for W
Min.	Max.	Min.	Max.	
0.575	0.74	14.61	18.8	A
0.635	0.905	16.13	22.99	B
0.805	1.06	20.45	26.92	C
0.89	1.22	22.61	30.99	D
1.09	1.31	27.48	33.27	E

X code

Conductor size AWG or kcmil		Connector only			
Stranded/ compressed	Solid/ compact	mm <sup>2</sup>	Connector only		X code
			Bi-metal**	Copper*	
–	#4	16.76	02500190	02702190	190
#4	#3	21.14	02500200	02702200	200
#3	#2	26.67	02500210	02702210	210
#2	#1	33.62	02500220	02702220	220
#1	1/0	42.41	02500230	02702230	230
1/0	2/0	53.49	02500240	02702240	240
2/0	3/0	67.43	02500250	02702250	250
3/0	4/0	85.01	02500260	02702260	260
4/0	250	107.2	02500270	02702270	270

\* Copper compression lug suitable for all copper conductors only.

\*\* Bi-metal compression lug with universal aluminum barrel suitable for copper or aluminum conductors.



## 600 A deadbreak separable connectors

### 600 series deadbreak components

600 Series deadbreak elbows, straight receptacles, junctions, vault stretchers and accessories are used to connect equipment and cable on primary feeder and network circuits. Designs accommodate large conductors and feature bolted connections and deadfront modular construction for maximum reliability, performance and versatility. De-energized connectors can be quickly and easily connected and disconnected using standard hand tools and equipment in accordance with accepted operating practices. Optional accessories allow visible external separation, bypass, isolation, dead-ending, grounding and testing as well as adding taps, surge arresters and circuit protection. Hotstick-operable and separable joint systems are shown on pages 28–34 and 45–48.

### Spiking aid

When spiking a medium voltage cable near a separable connector, the Elastimold<sup>®</sup> spiking aid is a specially designed product to reduce outage time and cost. Medium voltage cable is spiked as a means to ensure the circuit is de-energized where there is no sectionalizing device, direct testing means or provision for grounding.

### GAD

When available fault currents exceed 10 kA in underground systems, the Elastimold GAD may provide a solution. The Elastimold GAD is rated 25 kA and installs in the rear interface of a 600 series elbow connector (T-body). The GAD is normally covered and insulated with an insulating cap that contains capacitive test and a hotstick operating band. Once the circuit is opened at a disconnecting device, the test point cap is removed with a hotstick, and then using an appropriate capacitive test point meter, the test point is checked for voltage. The insulating cap is then removed with a hotstick and a high voltage meter is used to confirm the de-energized state before a ground cable is connected.

### Ratings overview

See pages 4–5 for complete information.

#### Current ratings

(Prefixes: 650, K650, K651, K655, K656, 750, 755, 756 and 03700)

- 600 A continuous
- 25 kA sym., 10 cycles

(Prefixes 675, K671, K675, K676, 775, 776 and 03702)

- 900 A continuous
- 25 kA sym., 10 cycles

Note: 900 A ratings require copper cable and copper current-carrying components.

#### Voltage ratings

15/25 kV class (5 kV thru 28 kV)

- 16.2 kV phase-to-ground
- 28 kV phase-to-phase
- 140 kV BIL
- 45 kV AC withstand
- 84 kV DC withstand
- 21.5 kV corona extinction

#### 35 kV class

- 21.1 kV phase-to-ground
- 36.6 kV phase-to-phase
- 150 kV BIL
- 50 kV AC withstand
- 103 kV DC withstand
- 26 kV corona extinction

Note: Elastimold has increased the IEEE Standard Production and Design Test levels for 25 kV class products to include 27 kV and 28 kV systems.

\* Tested at 8.3/14.9 kV

† Tested at 15.2/26.3 kV

• Tested at 21.1/36.6 kV

# 600 A deadbreak separable connectors

## 600 series deadbreak components

\* Tested at 8.3/14.9 kV  
 † Tested at 15.2/26.3 kV  
 • Tested at 21.1/36.6 kV

### Cable to equipment

See pages 84–93 for surge arrester applications.

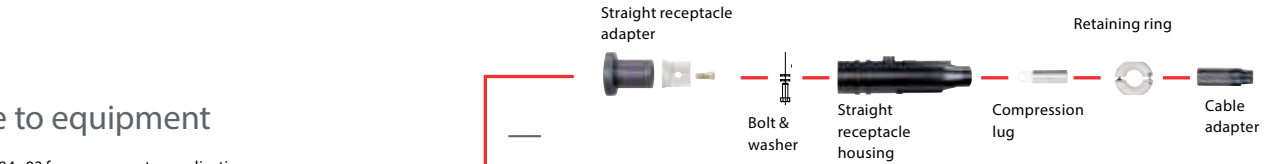

### Cable to cable (using junctions)

See pages 49–52 for additional junctions

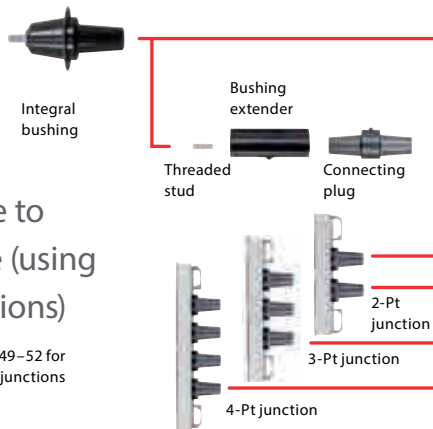

### Operating accessories

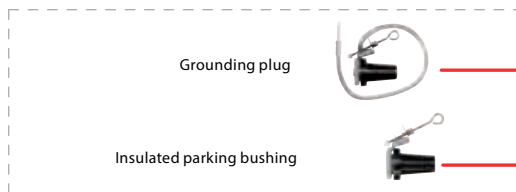





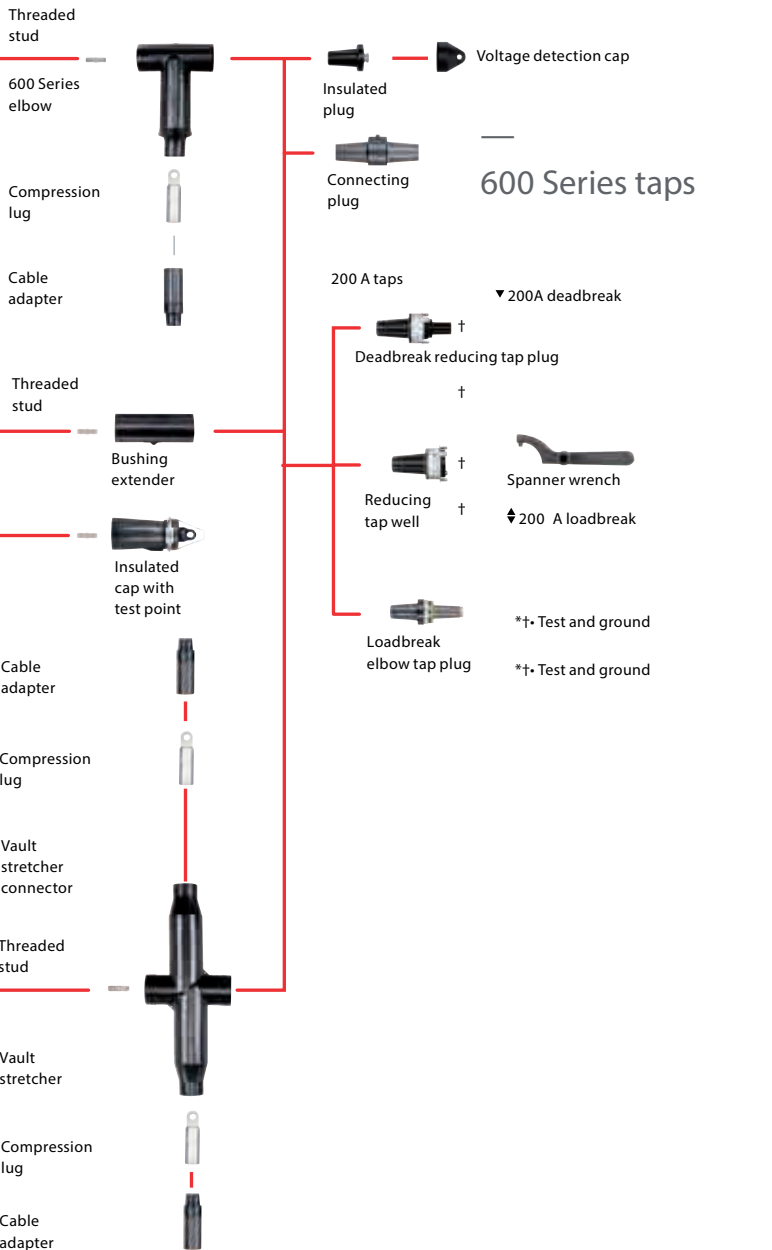





### Straight receptacle

### Elbow connector

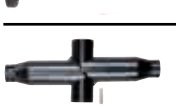

## 600 A deadbreak elbows

Image (not to scale)	Description	Voltage class (kV)	Cat. no.	Notes
	600 Series elbow (with insulating plug, cap, stud, lug and cable adapter)	15/25	K655LR-W0X Use tables W7 and X6	N1, 2
		35	755LR-W0X Use tables W9 and X6	N1, 2, 15
	600 Series direct test elbow (with insulating plug, cap, stud lug and cable adapter)	15/25	K655DLR-W0X Use tables W7 and X6	N1, 2, 12
		35	755DLR-W0X Use tables W9 and X6	N1, 2, 12, 15
	600 Series elbow with test point (with insulating plug, cap, stud, lug and cable adapter)	15/25	K656LR-W0X Use tables W7 and X6	N1, 2
		35	756LR-W0X Use tables W9 and X6	N1, 2, 15
	600 Series direct test elbow with test point (with insulating plug, cap, stud, lug and cable adapter)	15/25	K656DLR-W0X Use tables W7 and X6	N1, 2, 12
		35	756DLR-W0X Use tables W9 and X6	N1, 2, 12, 15
	600 Series elbow without test point housing only (with stud)	15/25	K655BLR	N1, 3
		35	755BLR	N1, 3, 15
	600 Series elbow with test point housing only (with stud)	15/25	K656BLR	N1, 3
		35	756BLR	N1, 3, 15
	600 Series straight receptacle (with cable adapter, lug and retaining ring)	15/25	K655SR-W0X Use tables W7 and X6	N1, 2, 11
	600 Series direct test straight receptacle elbow	15/25	K655DSR-W0X Use tables W7 and X6	N1, 2, 11, 12
	600 Series straight receptacle housing (lug and cable adapter not included)	15/25	K655BSR	N1, 11
	Straight receptacle adapter	15/25	K650SRA	N1, 4
	600 Series vault stretcher (housing only with stud)	15/25 kV	K655BVS	N1, 9
		35 kV	755BVS	N1, 9

N1. For 900 A ratings, substitute 675 for 650 and 655; 676 for 656; K671 for K651; K675 for K650 and K655; K676 for K656; 775 for 750 and 755; 776 for 756 and 2X for 0X in the catalog number. The 900 A rating requires copper current-carrying connector components and copper conductor cable.

N2. Add suffix symbol from page 71 to include cable shield grounding kit and/or cable jacket sealing kit.

N3. Available without the stud by adding "N" to the catalog number.

N4. Straight receptacle adapter is used to connect straight receptacles K655YBSR and K655YSR-W0X (50) to equipment bushings.

N5. Aluminum lug for use on aluminum or copper conductors.

DO NOT substitute threaded 03600X lug.

N6. Copper lug for use on COPPER CONDUCTOR ONLY.

DO NOT substitute threaded 03602X lug.

N7. Available with the stud factory-assembled by adding "SP" to the catalog number. 675ETP, K675ETP and 775ETP are available as -SP only. The stud is not field removable.

N8. Available with a loose stud by adding suffix "S" to the catalog number.

N9. 600SW spanner wrench is recommended for installation of deadbreak reducing tap plugs and reducing tap wells.

N10. Use 600ATM assembly tool.

N11. 600 Series elbows and straight receptacles with IEEE Std. 386 capacitive test points are available by substituting 656 for 655; K656 for K655; K676 for K675; 756 for 755; 676 for 675; K676 for K675 and 776 for 775 in the catalog number.

N12. Direct test connectors, along with a 200TC-X series meter adapter, a properly rated voltage meter and hot-line stick; provides a means for direct conductor voltage testing.

N13. With stainless steel bracket.

N15. Available with 200 kV BIL adding suffix "-200".























N16. Bimetallic Lug for use on aluminum or copper conductors. DO NOT substitute threaded 05501X lug

Refer to the W and X tables on pages 80–81 for sizing to cable insulation diameter and conductor size. For cable shield adapters and jacket seals, see pages 70–71.

## 600 A deadbreak separable connectors

### 600 series deadbreak components

#### 600 A deadbreak accessories

Image (not to scale)	Description	Voltage class (kV)	Cat. no.	Notes
	Cable size adapter	15/25	655CA-W Use tables W7	-
		35	755CA-W Use tables W9	-
	Compression lug	All	03700X Use tables X6	N5
		All	03702X Use tables X6	N6
	Bimetallic compression lug	All	04601XXX Use Table X6	N16
	Epoxy connecting plug	15/25	K650CP	N9
	600 Series elbow and vault stretcher size sensitive kit (cable adapter and lug)	15/25	655CK-W0X Use tables W7 and X6	N2
		35	755CK-W0X Use tables W9 and X6	N2
	Adapter retaining ring	All	650ARR-X Use Table X6	-
	600 Series straight receptacle size sensitive kit (cable adapter, retaining ring and lug)	15/25	655CK-W0X-ARR Use tables W7 and X6	N2
	Bushing extender (with stud)	15/25	K655BE	N1, 3
		35	755BE	N1, 3
	Insulated cap with test point (with stud)	15/25	K656DR	N3, 7
		35	756DR	-
	Insulated cap with test point (with stud) and ground	15/25	K656DRG	N3, 7
		35	756DRG	-
	Insulating plug (with cap)	15/25	K650BIP	N1, 7, 8
		35	750BIP	N1, 7, 8
	Grounding plug (ground lead 2/0 AWG x 30")	15/25	650GP	N1, 7, 8
		35	750GP	N1, 7, 8
	Insulated parking bushing	15/25	K650SOP	N7, 8
		35	750SOP	N7, 8
	Connecting plug	15/25	K651CP	N1, 7, 8, 10
		35	750CP	N1, 7, 8, 10
	Deadbreak reducing tap plug	15/25	K650RTP	N1, 7, 8, 9
	Reducing tap well	15/25	K650RTW	N1, 7, 8, 9
	Loadbreak elbow tap plug	15	650ETP	N1, 7, 8, 10
		25	K650ETP	N1, 7, 8, 10
		35	750ETP	N1, 7, 8, 10
	Vault stretcher threaded stud	15/25	650VSA	N1
		35	750VSA	N1
	600 Series elbow threaded stud	15/25	650SA	N1
		35	750SA	N1
	Assembly tool (window-op)	All	600ATM	-
	Spanner wrench	All	600SW	N9
	Direct voltage test meter adapter for: HD electric meters	All	200TC-1	N12
	Ross meters		200TC-2	N12
	Chance meters		200TC-4	N12

N1. For 900 A ratings, substitute 675 for 650 and 655; 676 for 656; K671 for K651; K675 for K650 and K655; K676 for K656; 775 for 750 and 755; 776 for 756 and 2X for 0X in the catalog number. The 900 A rating requires copper current-carrying connector components and copper conductor cable.

N2. Add suffix symbol from page 71 to include cable shield grounding kit and/or cable jacket sealing kit.

N3. Available without the stud by adding "N" to the catalog number.  
N4. Straight receptacle adapter is used to connect straight receptacles K655YBSR and K655YSR-W0X (50) to equipment bushings.

N5. Aluminum lug for use on aluminum or copper conductors. DO NOT substitute threaded 03600X lug.

N6. Copper lug for use on COPPER CONDUCTOR ONLY. DO NOT substitute threaded 03602X lug.

N7. Available with the stud factory-assembled by adding "SP" to the catalog number. 675ETP, K675ETP and 775ETP are available as -SP only. The stud is not field removable.

N8. Available with a loose stud by adding suffix "S" to the catalog number.

N9. 600SW spanner wrench is recommended for installation of deadbreak reducing tap plugs and reducing tap wells.

N10. Use 600ATM assembly tool.  
N11. 600 Series elbows and straight receptacles with IEEE Std. 386 capacitive test points are available by substituting 656 for 655; K656 for K655; K676 for K675; 756 for 755; 676 for 675; K676 for K675 and 776 for 775 in the catalog number.

N12. Direct test connectors, along with a 200TC-X series meter adapter, a properly rated voltage meter and hot-line stick; provides a means for direct conductor voltage testing.

N13. With stainless steel bracket.  
N15. Available with 200 kV BIL adding suffix "-200".

N16. Bimetallic lug for use on aluminum or copper conductors. DO NOT substitute threaded 05501X lug.

Refer to the W and X tables on pages 80-81 for sizing to cable insulation diameter and conductor size. For cable shield adapters and jacket seals, see pages 70-71.

## Ordering information

The following diagram shows how to construct a catalog number for a 600 A deadbreak elbow connector:

Indicates field that must be filled in to complete the catalog number.

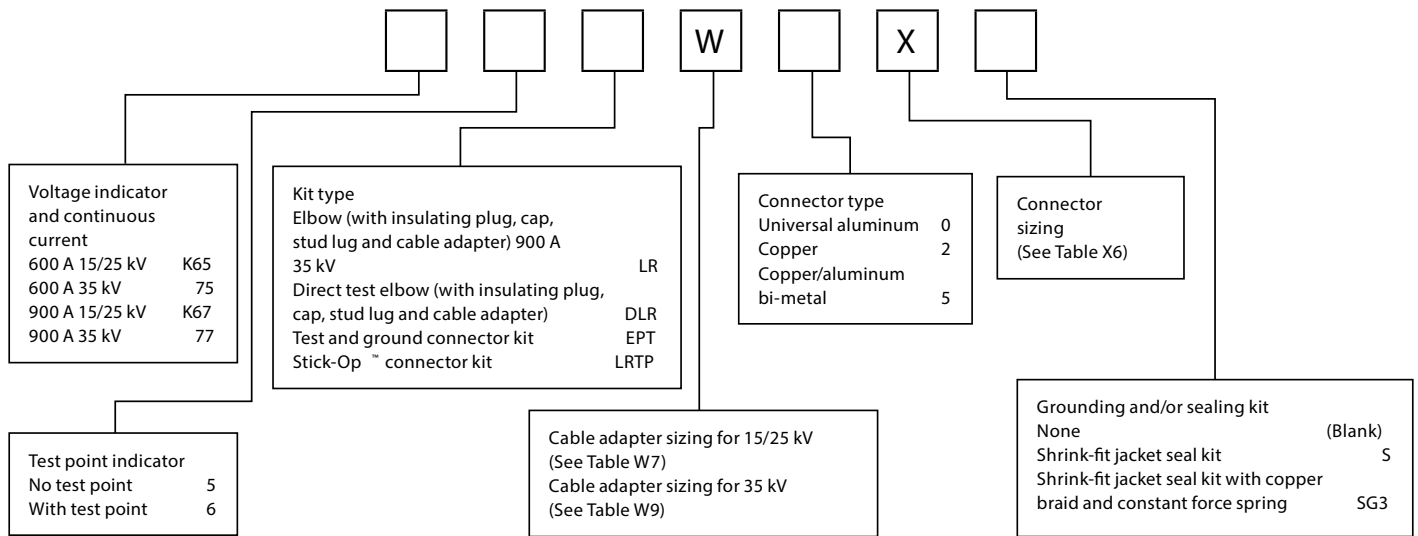

Table W7 – Cable adapter sizing for 15/25 kV

Cable insulation dia. range		Cable insulation diameter in millimeters		Symbol for W
Min.	Max.	Min.	Max.	
0.420	0.660	10.7	16.8	D
0.530	0.680	13.5	17.3	E
0.640	0.820	16.3	20.8	F
0.760	0.950	19.3	24.1	G
0.850	1.050	21.6	26.7	H
0.980	1.180	24.9	4.6	J
1.090	1.310	27.7	33.3	K
1.180	1.465	30.0	37.2	L
1.280	1.430	32.5	36.3	LM
1.370	1.630	34.8	41.4	M
1.550	1.780	39.4	45.2	N
1.725	1.935	43.8	49.1	P

Table W9 – Cable adapter sizing for 35 kV

Cable insulation dia. range		Cable insulation diameter in millimeters		Symbol for W
Min.	Max.	Min.	Max.	
0.760	0.950	19.3	24.1	G
0.850	1.050	21.6	26.7	H
0.980	1.180	24.9	30.0	J
1.090	1.310	27.7	33.3	K
1.180	1.465	30.0	37.2	L
1.370	1.630	34.8	41.4	M
1.515	1.780	38.5	45.2	N
1.725	1.935	43.8	49.1	P
1.900	2.120	48.3	53.8	Q
2.115	2.235	53.7	56.8	R

Table X6 – Connector sizing

AWG or kcmil	Stranded/compressed	Solid/compact	Code
-	-	#2	210
#2	-	#1	220
#1	-	1/0	230
1/0	-	2/0	240
2/0	-	3/0	250
3/0	-	4/0	260
4/0	-	250	270
250	-	300	280
300	-	350	290
350	-	400	300
400	-	450	310
450	-	500/550	320
500	-	600	330
550	-	650	340
600	-	700	350
650	-	750/800	360
700/750	-	900	380
800	-	-	390
900	-	1000	400
1000	-	-	410
-	-	1250	420
1250	-	-	440

## 600 A deadbreak elbow separable connectors

### 600 series deadbreak components

600 series deadbreak elbows, straight receptacles, junctions, vault stretchers and accessories are used to connect equipment and cable on primary feeder and network circuits. Designs accommodate large conductors and feature bolted connections and deadfront modular construction for maximum reliability, performance and versatility.

De-energized connectors can be quickly and easily connected and disconnected using standard hand tools and equipment in accordance with accepted operating practices. Optional accessories allow visible external separation, bypass, isolation, dead-ending, grounding and testing as well as adding taps, surge arresters and circuit protection.

Hotstick operable and separable joint systems are shown on pages 28–34 and 45–48.

Elastimold<sup>®</sup> junctions are designed for subsurface, vault or padmount applications and can be used for sectionalizing, looping, tapping and equipment bypass. Junctions are designed to mate with other Elastimold products including:

- K655 elbow connector
- K655BE bushing extender
- 655BEA3 bushing adapter

Elastimold junctions are equipped with a stainless steel mounting bracket and back plate suitable for mounting on a flat surface.

### Features

- 15/25 kV and 35 kV, 600 A deadbreak
- 2-Way, 3-way and 4-way junctions
- 200 kV BIL is available for the 35 kV products
- Fully shielded, fully submersible molded rubber housing
- Stainless steel mounting bracket



### Ratings overview

See 4–5 for complete information.

#### Current ratings

(Prefixes: 650, K650, K651, K655, K656, 750, 755, 756 and 03700)

- 600 A continuous
- 25 kA sym., 10 cycles

(Prefixes 675, K675, K671, K676, 775, 776 and 03702)

- 900 A continuous
- 25 kA sym., 10 cycles

Note: 900 A ratings require copper cable and copper current-carrying components.

#### Voltage ratings

15/25 kV class (5 kV through 28 kV)

- 16.2 kV phase-to-ground
- 28 kV phase-to-phase
- 140 kV BIL
- 45 kV AC withstand
- 84 kV DC withstand
- 21.5 kV corona extinction
- 35 kV class
- 21.1 kV phase-to-ground
- 36.6 kV phase-to-phase
- 150 kV BIL
- 50 kV AC withstand
- 103 kV DC withstand
- 26 kV corona extinction

Note: Elastimold has increased the IEEE Standard Production and Design Test levels for 25 kV class products to include 27 kV and 28 kV systems.

\* Tested @ 8.3/14.9 kV

† Tested @ 15.2/26.3 kV

• Tested @ 21.1/36.6 kV

## Separable connectors 600 series deadbreak

See pages 84–93 for surge arrester applications.

Cable to equipment

Cable to cable (using junctions)

Operating accessories

Hotstick operable 600 series connectors

See pages 28–34

Threaded compression lug

Stick-Op loadbreak reducing tap plug

Cam-Op retainer sleeves

Cam-Op link connector

Straight receptacle

Elbow connector

600 Series taps

Cable to cable using L-kits



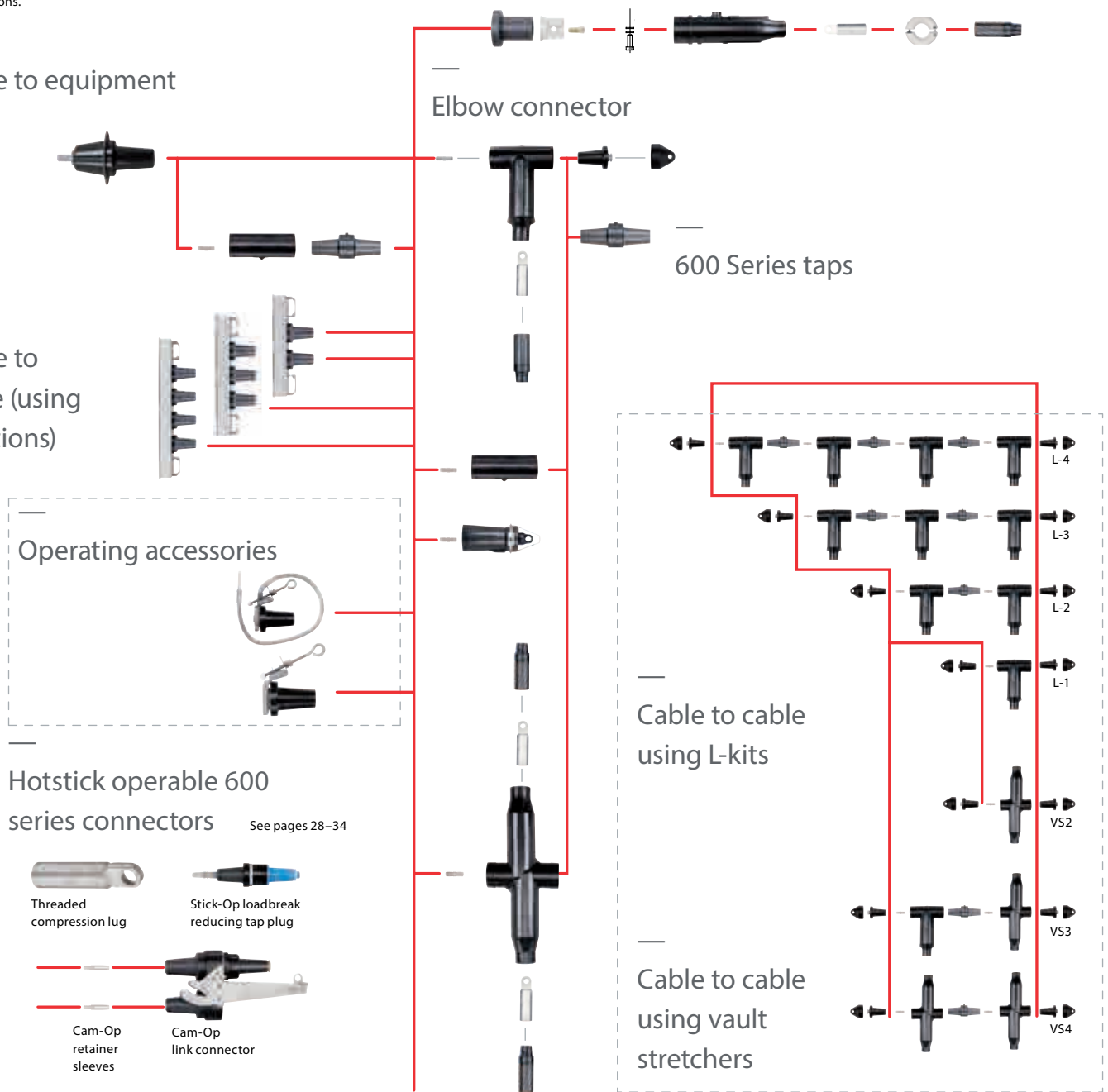







Cable to cable using vault stretchers



## 600 A deadbreak elbow separable connectors

### 600 series deadbreak components

#### 600 series deadbreak components

Image (not to scale)	Description	Voltage class (kV)	Cat. no.	Notes
	2-point junction	15/25 35	K650J2 750J2	N1, 7, 8 N1, 7, 8, 11
	3-point junction	15/25 35	K650J3 750J3	N1, 7, 8 N1, 7, 8, 11
	4-point junction	15/25 35	K650J4 750J4	N1, 7, 8 N1, 7, 8, 11
	1-way L-kit	15/25 35	K655L1 755L1	N1, 2, 3, 9, 10 N1, 2, 3, 11
	2-way L-kit	15/25 35	K655L2-WOX 755L2-WOX	N1, 2, 3, 4, 5, 6, 9, 10 N1, 2, 3, 4, 5, 6, 11
	2-way VS-kit	15/25 kV 35 kV	K655VSL2-WOX 755VSL2-WOX	N1, 2, 3, 9, 10 N1, 2, 3, 11
	3-way L-kit	15/25 35	K655L3-WOX 755L3-WOX	N1, 2, 3, 4, 9, 10 N1, 2, 3, 4, 11
	3-way VS-kit	15/25 35	K655VSL3-WOX 755VSL3-WOX	N1, 2, 3, 5, 6, 9, 10 N1, 2, 3, 5, 6, 11
	4-way L-kit	15/25 35	K655L4-WOX 755L4-WOX	N1, 2, 3, 4, 9, 10 N1, 2, 3, 4, 11
	4-way VS-kit	15/25 35	K655VSL4-WOX 755VSL4-WOX	N1, 2, 3, 5, 6, 9, 10 N1, 2, 3, 5, 6, 11
	Assembly tool	All	600ATM	

N1. For 900 A ratings, substitute 675 for 650 and 655; 676 for 656; K675 for K650 and K655; K676 for K656; 775 for 750 and 755; 776 for 756 and 2X for 0X in the catalog number. The 900 A rating requires copper current-carrying connector components and copper conductor cable.

N2. L-Kits and VS-Kits do not include cable adapters or compression lugs. These items must be ordered separately.

N3. 600 Series Elbows and Straight Receptacles with IEEE Std. 386 capacitive test points are available by substituting 656 for 655; K656 for K655; K676 for K675; 756 for 755; 676 for 675; K676 for K675 and 776 for 775 in the catalog number.

N4. 600ATM is recommended for installing K651CP and 750CP.

N5. Can be used as a repair joint mounting hardware.

(Gains 3 ½" of repair length.)

N6. Can be used as a reducing joint for different size cables.

N7. Rubber junction with stainless steel mounting plate and back plate.

Add "-U" for rubber junction with stainless steel mounting plate, back plate and adjustable mounting bracket. Add "-4" for rubber junction only.

Add "-5" for rubber junction, stainless steel U-straps and back plate.

Add "-6" Hardware package consists of brackets and straps only.

N8. Two - six-position multi-point junctions shown on pages 22–23.

N9. Replace "L" for "E" when connecting to equipment and one BIP

is not required (i.e., K655E2, K655E3, K655VSE3).

N10. Add "G" after "L" to replace a BIP with a GAD + GADDR or "GB" for a BGAD+BGADDR (i.e., K655EG2, K655LGB3, K655VSEG3).

N11. Available with 200 kV BIL adding suffix "-200".

Refer to the next for L-kits and vault stretcher kits ordering information.



## L-kits and vault stretcher kits ordering information

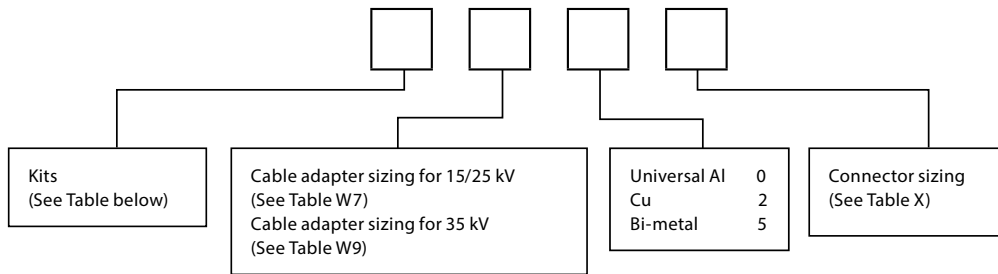

Kits

Kits	15/25 kV	35 kV
1-way L-kit	K655L1	755L1
2-way L-kit	K655L2	755L2
3-way L-kit	K655L3	755L3
4-way L-kit	K655L4	755L4
2-way VS-kit	K655VSL2	755VSL2
3-way VS-kit	K655VSL3	755VSL3
4-way VS-kit	K655VSL4	755VSL4

Table W7 – Cable adapter sizing for 15/25 kV

For 15/25 kV				
Cable insulation diameter in inches		Cable insulation diameter in millimeters		Symbol for W
Min.	Max.	Min.	Max.	
0.640	0.820	16.256	20.828	F
0.760	0.950	19.304	24.130	G
0.850	1.050	21.590	26.670	H
0.980	1.180	24.892	29.972	J
1.090	1.310	27.686	33.274	K
1.180	1.465	29.972	37.211	L
1.280	1.430	32.512	36.322	LM
1.370	1.630	34.798	41.402	M
1.550	1.780	38.481	45.212	N
1.725	1.935	43.815	49.149	P

Table W9 – Cable adapter sizing for 35 kV

For 35 kV				
Cable insulation diameter in inches		Cable insulation diameter in millimeters		Symbol for W
Min.	Max.	Min.	Max.	
0.760	0.950	19.304	24.130	G
0.850	1.050	21.590	26.670	H
0.980	1.180	24.892	29.972	J
1.090	1.310	27.686	33.274	K
1.180	1.465	29.972	37.211	L
1.280	1.430	32.512	36.322	LM
1.370	1.630	34.798	41.402	M
1.550	1.780	38.481	45.212	N
1.725	1.935	43.815	49.149	P
1.900	2.120	48.260	53.848	Q

Table X – Connector sizing

	AWG or kcmil		mm <sup>2</sup>	Connector only		
	Strand./compr.	Solid/compact		Compact	Universal aluminum	Copper
210	–	2	–	03700210	03702210	04601210
220	2	1	35	03700220	03702220	04601220
230	1	1/0	50	03700230	03702230	04601230
240	1/0	2/0	–	03700240	03702240	04601240
250	2/0	3/0	70	03700250	03702250	04601250
260	3/0	4/0	95	03700260	03702260	04601260
270	4/0	250	125	03700270	03702270	04601270
280	250	300	–	03700280	03702280	04601280
290	300	350	150	03700290	03702290	04601290
300	350	400	185	03700300	03702300	04601300
310	400	450	240	03700310	03702310	04601310
320	450	500/550	–	03700320	03702320	04601320
330	500	600	250/300	03700330	03702330	04601330
340	550	650	–	03700340	03702340	04601340
350	600	700	400	03700350	03702350	03705350
360	650	750/800	–	03700360	03702360	04601360
380	700/750	900	–	03700380	03702380	04601380
390	800	–	500	03700390	03702390	04601390
400	900	1000	–	03700410	03702410	04601410
410	1000	–	–	03700410	03702410	04601410
420	–	1250	–	03700420	03702420	04601420
440	1250	–	–	03700440	03702440	04600440

## 600 A deadbreak elbow separable connectors

### 600 series Cam-Op™ deadbreak connector system

The Elastimold® 600 series Cam-Op deadbreak connector system incorporates provisions for hotstick operation of de-energized primary feeder or network circuits. Configurations allow external visible break, testing, grounding and isolation. Retrofit kits allow upgrading existing equipment.

The Cam-Op system utilizes pin and socket connectors and can be retrofitted to existing equipment. The Cam-Op connector is easily installed or removed by hotstick operation of the cam-action disconnect lever.

#### Features

- 15/25 and 35 kV, 600 A deadbreak-rated Cam-Op link
- Provides 200 A tap for testing and grounding connections
- Cam-Op lever for hotstick operation and easy installation and removal
- Visi-Break series provides for independent isolation of circuits

#### Ratings overview

See pages 4–5 for complete information.

##### Current ratings

600 A and 900 A continuous  
25 kA sym., 10 cycles

Note: 900 A ratings require copper cable and copper current-carrying components.

##### Continuous voltage ratings

15 kV class

- 8.3 kV phase-to-ground
- 14.4 kV phase-to-phase
- 95 kV BIL
- 34 kV AC withstand
- 53 kV DC withstand
- 11 kV corona extinction

25 kV class

- 15.2 kV phase-to-ground
- 26.3 kV phase-to-phase
- 125 kV BIL
- 40 kV AC withstand
- 78 kV DC withstand
- 19 kV corona extinction

35 kV class

- 21.1 kV phase-to-ground
- 36.6 kV phase-to-phase
- 150 kV BIL
- 50 kV AC withstand
- 103 kV DC withstand
- 26 kV corona extinction





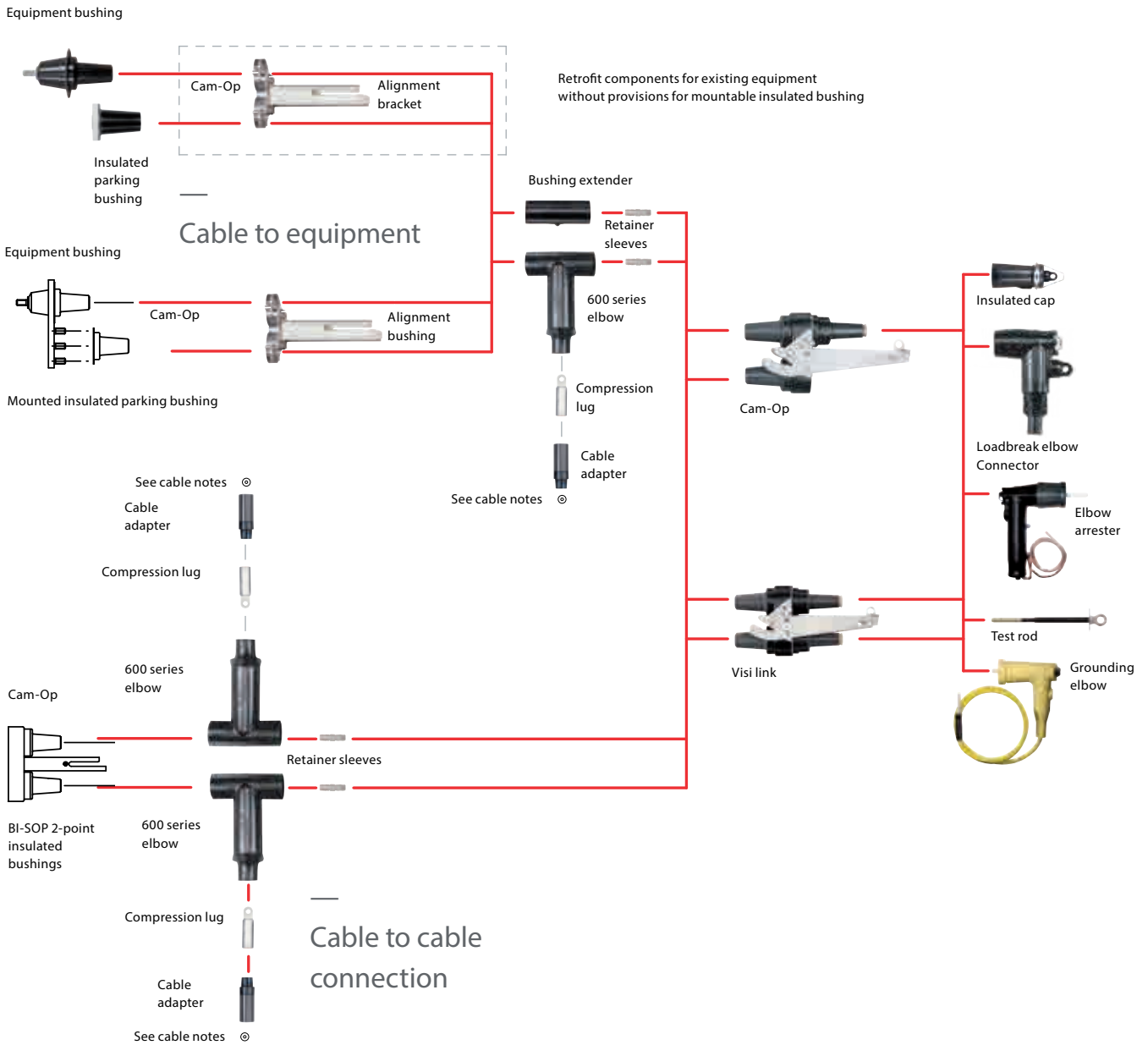









# Cam-Op™ system – 600 series deadbreak



## 600 A deadbreak elbow separable connectors

### 600 series Cam-Op™ deadbreak connector system

#### 600 series Cam-Op system

Image (not to scale)	Description	Voltage class (kV)	Cat. no.	Notes
	Cam-Op connector kit	15	655LINK-C-LR-W0X-B-DRG Use tables W7 and X6	N1, 2, 8, 10, 11, 12
		25	K655LINK-C-LR-W0X-B-DRG Use tables W7 and X6	N1, 2, 8, 10, 11, 12
		35	755LINK-C-LR-W0X-B-DRG Use tables W9 and X6	N1, 2, 8, 10, 11, 12
	Mountable insulated bushing	25	K650LBM-3	N2
		35	750LBM-3	N2
	Retrofit Cam-Op connector kit	15	655LINK-C-LR-W0X-A-DRG Use tables W7 and X6	N4, 8, 10, 11, 12
		25	K655LINK-C-LR-W0X-A-DRG Use tables W7 and X6	N4, 8, 10, 11, 12
		35	755LINK-C-LR-W0X-A-DRG Use tables W9 and X6	N4, 8, 10, 11, 12
	Insulating plug	25	K650LB	N3
		35	750LB	N3
	Cam-Op alignment bracket	15	650CAB	–
		25	K650CAB	–
		35	750CAB	–
	Compression lug	All	03700X Use table X6	N5
			03702X Use table X6	N6
			04601X	–
	Cam-Op size sensitive kit (cable adapter and lug)	15/25	655CK-W0X Use tables W7 and X6	N10
		35	755CK-W0X Use tables W9 and X6	N10
	Cam-Op retaining sleeve	All	650RSC	N8
	Cam-Op cable joint kit	15	655BI-LINK-C-LR-W0X-DRG Use tables W7 and X6	N7, 8, 10, 11, 12
		25	K655BI-LINK-C-LR-W0X-DRG Use tables W7 and X6	N7, 8, 10, 11, 12
		35	755BI-LINK-C-LR-W0X-DRG Use tables W9 and X6	N7, 8, 10, 11, 12
	Cam-Op loadbreak reducing tap plugs (visi-break)	15	650LK-C-VB	–
		25	K650LK-C-VB	–
		35	750LK-C-VB	–
	Cam-Op link	15	650LK-C	–
		25	K650LK-C	–
		35	750LK-C	–
	Grounding elbow (1/0 AWG x 6' ground lead)	15	160GLR	–
		25	370GLR	N 13
		35	370GLR	N 13
	Test rod	All	370TR	–

N1. Cam-Op connector kit includes: (1) Cam-Op link; (1) elbow housing; (1) cable adapter; (1) 0370 style lug; (1) bushing extender; (2) retainer sleeves; (1) insulated cap; (1) mountable insulated bushing and (1) alignment bracket.

N2. Mountable insulated bushing included with Cam-Op connector kit. Requires three threaded studs on equipment faceplate for installation. N3. Use with the retrofit Cam-Op connector kit.

N4. Retrofit Cam-Op connector kit includes: (1) link; (1) elbow housing; (1) cable adapter; (1) 0370 style lug; (1) bushing extender; (2) retainer sleeves; (1) insulated cap; (1) insulating plug; and (1) alignment bracket. N5. Aluminum lug for use on aluminum or copper conductors. DO NOT substitute threaded 03600X lug.

N6. Copper lug for use on COPPER CONDUCTOR ONLY. DO NOT substitute 03602X threaded lug.

N7. Cam-Op cable joint kit includes: (1) Cam-Op link; (1) Cam-Op BI-SOP; (2) elbow housings; (2) cable adapters; (2) 0370 style lugs; (2) retainer sleeves; (1) insulated cap.

N8. 600ATM is recommended for installing Cam-Op retaining sleeves.

N9. For 900-amp ratings, substitute 675 for 650 and 655; 676 for 656; K675 for K650 and K655; K676 for K656; 775 for 750 and 755; 776 for 756 and 2X for 0X in the catalog number. The 900-amp rating requires copper current-carrying connector components and copper conductor cable.

N10. Add suffix symbol from page 71 to include cable shield grounding kit and/or cable jacket sealing kit.

N11. To add elbows or arresters instead of insulating caps, replace the "DRG" with "LR-WX" for elbows (with test point) or "ESA" for elbow arresters.

N12. 600 series elbows with IEEE 386 capacitive test points are available by substituting 656 for 655; K656 for K655; K676 for K675; 756 for 755; 676 for 675; K676 for K675 and 776 for 775 in the catalog number.

N13. Rated for both 25 kV and 35 kV applications.

Refer to the W and X tables on pages 80–81 for sizing to cable insulation diameter and conductor size. For cable shield adapters and jacket seals, see pages 70–71.

## 600 series test and ground and Stick-Op™ deadbreak connector systems

The Elastimold® 600 series test and ground and Stick-Op deadbreak connector systems incorporate provisions for hotstick operation of de-energized primary feeder or network circuits.

The test and ground and Stick-Op connectors allow direct testing and grounding with no required cable movement.

Test and ground is ideal for equipment applications that include viewing windows to provide an internal visible break and that do not require hotstick removal of the elbows.

Stick-Op provides an external visible break by hotstick removal of the elbow.

Test and ground and Stick-Op connectors are bolted and installed using torque-controlled tools.

### Ratings overview

See pages 4–5 for complete information.

#### Current ratings

- 600 A and 900 A continuous
- 25 kA sym., 10 cycles

Note: 900 A ratings require copper cable and copper current-carrying components.

#### Continuous voltage ratings

##### 15 kV class

- 8.3 kV phase-to-ground
- 14.4 kV phase-to-phase
- 95 kV BIL
- 34 kV AC withstand
- 53 kV DC withstand
- 11 kV corona extinction

##### 25 kV class

- 15.2 kV phase-to-ground
- 26.3 kV phase-to-phase
- 125 kV BIL
- 40 kV AC withstand
- 78 kV DC withstand
- 19 kV corona extinction

##### 35 kV class

- 21.1 kV phase-to-ground
- 36.6 kV phase-to-phase
- 150 kV BIL
- 50 kV AC withstand
- 103 kV DC withstand
- 26 kV corona extinction

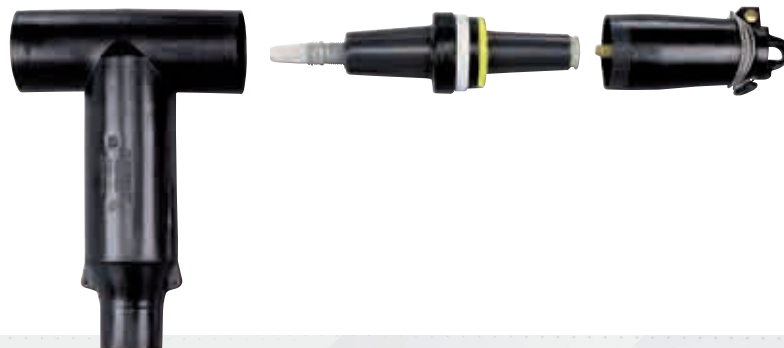



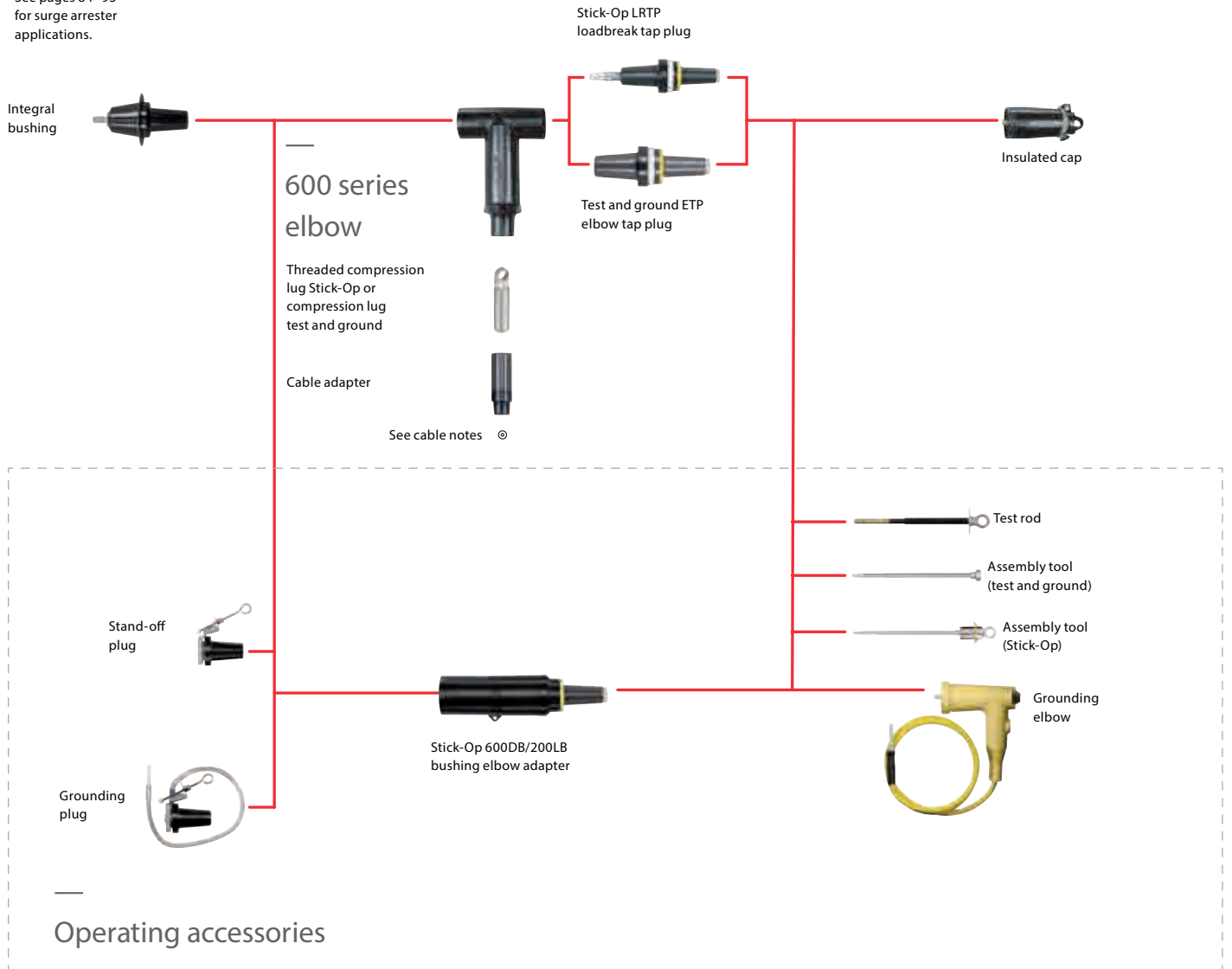

# 600 A deadbreak elbow separable connectors 600 series test and ground and Stick-Op™ deadbreak connector systems

## Stick-Op and test and ground system – 600 series deadbreak

See pages 84–93  
for surge arrester  
applications.















## Stick-Op kits

Image (not to scale)	Description	Voltage class (kV)	Cat. no.	Notes
	Test and ground connector kit	15	655ETP-W0X-DRG Use tables W7 and X6	N1, 4, 5, 6, 11, 13
		25	K655ETP-W0X-DRG Use tables W7 and X6	
		35	755ETP-W0X-DRG Use tables W9 and X6	
	Test and ground replacement connector kit	15	655RETP	N4, 5, 6, 11, 13, 14
		25	K655RETP	
	Stick-Op connector kit	15	655LRTP-W0X-DRG Use tables W7 and X6	N2, 3, 4, 5, 8, 11
		25	K655LRTP-W0X-DRG Use tables W7 and X6	
		35	755LRTP-W0X-DRG Use tables W9 and X6	
	Stick-Op replacement connector kit	15	655RLRTP	N3, 4, 5, 8, 11, 14
		25	K655RLRTP	

## 600 A deadbreak elbow separable connectors

### 600 series test and ground and Stick-Op™ deadbreak connector systems

#### Stick-Op accessories

Image (not to scale)	Description	Voltage class (kV)	Cat. no.	Notes
	Stick-Op size-sensitive kit (cable adapter and threaded lug)	15/25	655TCK-W0X Use tables W7 and X6	N5
		35	755TCK-W0X Use tables W9 and X6	N5
	Extraction tool	All	650ET	N10
	Grounding elbow (1/0 AWG x 6' ground lead)	15	160GLR	-
		25	370GLR	N12
		35	370GLR	N12
	Test rod	All	370TR	-
	Assembly tool (Stick-Op)	All	600AT	N3
	Assembly tool (test and ground)	All	600ATM	N13
	Test and ground loadbreak elbow tap plug	15	650ETP	N4, 13, 16
		25	K650ETP	N4, 13, 16
		35	750ETP	N4, 13, 16
	Stick-Op loadbreak reducing tap plug	15	650LRTPA3	N3, 4
		25	K650LRTPA2	-
		35	750LRTPA2	-
	Stick-Op bushing adapter	15	655BEA3	N3, 4
		25	K655BEA2	-
		35	755BEA2	-
	Compression lug test and ground	All	03700X Use tables X6	N6
		All	03702X Use tables X6	N7
	Threaded compression lug Stick-Op	All	03600X Use tables X6	N8, 15
		All	03602X Use tables X6	N9
	Test and ground size-sensitive kit (cable adapter and lug)	15/25	655CK-W0X Use tables W7 and X6	N4, 5
		35	755CK-W0X Use tables W9 and X6	N4, 5

N1. Test and ground kit includes: insulated cap; test and ground reducing tap plug; 600 series elbow housing; cable adapter; and 0370 style compression lug.

N2. Stick-Op kit includes insulated cap; Stick-Op loadbreak reducing tap plug; 600 series elbow housing; cable adapter; and threaded 0360 style compression lug.

N3. 600AT assembly tool required for operation and/or installation of Stick -Op.

N4. For 900 A ratings, substitute 675 for 650 and 655; 676 for 656; K675 for K650 and K655; K676 for K656; 775 for 750 and 755; 776 for 756 and 2X for 0X in the catalog number. The 900 A rating requires copper current-carrying connector components and copper conductor cable.

N5. Add suffix symbol from page 71 to include cable shield grounding kit and/or cable jacket sealing kit.

N6. Aluminum lug for use on aluminum or copper conductors.

DO NOT substitute threaded 03600X lug.

N7. Copper lug for use on COPPER CONDUCTOR ONLY.

DO NOT substitute 03602X threaded lug.

N8. Threaded aluminum lug (Stick-Op only) for use on copper or aluminum conductors. DO NOT substitute unthreaded 03700X lugs.

DO NOT use with 675, 676, K675, K676, 775 or 776 catalog numbers.

N9. Threaded copper lug (Stick-Op only) for use on copper conductors only. DO NOT substitute unthreaded 03702X lugs.

N10. Required to disassemble Stick-Op loadbreak reducing tap plug from the threaded compression lug and 600 series elbow after the shear-pin is broken during assembly.

N11. 600 series Elbows with IEEE 386 capacitive test points are available by substituting 656 for 655; K656 for K655; K676 for K675; 756 for 755; 676 for 675; K676 for K675 and 776 for 775 in the catalog number.

N12. Rated for both 25 kV and 35 kV applications.

N13. 600ATM assembly tool required for test and ground assembly. 50-60 ft./lbs. torque wrench required but not included.

N14. Replacement elbow includes: insulated cap; reducing tap plug; 600 series elbow housing; I-adapter; straight receptacle, resulting in a net gain of 20" in length vs. a standard elbow kit. Compression lugs and cable adapters are ordered separately.

N15. Retrofit sleeve to convert 03600X series lug to a 03700X series lug (catalog number 650-353).

N16. Add "SP" to the part number to include factory-assembled stud.

Refer to the W and X tables on pages 80-81 for sizing to cable insulation diameter and conductor size. For cable shield adapters and jacket seals, see pages 70-71.



## Grounding-aid device (GAD)

### Don't chance grounding safety

When available fault currents exceed 10 kA in underground systems, the Elastimold™ grounding-aid device (GAD) is a solution.

The GAD provides a permanent, reliable, direct 600 A or 900 A, 25 kA-rated ground connection without the need to reconfigure or install additional equipment such as reducing plugs or other temporary grounding adapters. The GAD comes complete with a removable protective cap with capacitive test point that allows easy access to check if the system is de-energized and designed to be hotstick workable.

#### Application

The Elastimold GAD is rated 25 kA and easily installs in the rear interface of a 600 A series elbow connector (T-body), providing a direct and permanent grounding connection, saving time, money and resources. It also supports faster system restoration by eliminating the need for configuring additional adapters and work steps.

The associated insulating cap with integral capacitive test point is conveniently located to help check that the circuit is de-energized and is completely hotstick workable.

Once the circuit is de-energized, it is grounded through a grounding cable to the grounding system. The GAD is available with both straight or ball receptacles for maximum ground clamp flexibility.

#### Features

- Available for 15/25 kV and 35 kV
- Short circuit withstand up to 25 kA, full copper construction ideal for 600 A and 900 A applications
- Provides a safe, highly reliable and visible direct connection to ground
- Includes insulated cap with capacitive test point
- Eliminates the need to install temporary grounding adapters
- Provides a direct test point and grounding connection for maximum personnel safety
- Elastimold-exclusive product design available in 15, 25 and 35 kV system classes
- Available for C and ball-stud grounding clamp types\*

\*Series GAD and GADDR are designed for standard C-clamp ground connections, and series BGAD and BGADDR are specifically designed for ball-stud ground connections.

## Grounding-aid device (GAD)



### Grounding connections

Illustration (not to scale)	Description	Voltage class (kV)	Cat. no.	Notes
	600 series grounding device kit	15/25	K676GADDRK	-
	600 series grounding device with ball kit	15/25	K676BGADDRK	N2
	600 series grounding device with 20 mm ball kit	15/25	K676B20GADDRK	N2
	600 series grounding device kit	35	776GADDRK	N1
	600 series grounding device with ball kit	35	776BGADDRK	N1, 2
	600 series grounding device with 20 mm ball kit	35	776B20GADDRK	N1, 2
	BGAD 1" hex deep socket	-	600-570	-

N1. Available with 200 kV BIL by adding suffix "-200".

N2. Part number 600-570 required to install (1" hex deep socket).

Refer to the W and X tables on pages 80-81 for sizing to cable insulation diameter and conductor size. For cable shield adapters and jacket seals, see pages 70-71.

## 600 A spiking aid cable accessories

—  
01 K655ELR  
—  
02 K656CHSL-HP

600 series separable cable joints with spiking aid option are available in spiking aid T and 2-, 3- and 4-way versions and include a capacitive test point as standard.

Units are interchangeable, featuring bolted connections. Designs are compact and ideally suited for small vaults and manholes.

### Spiking aid T

The spiking aid feature is available in the extended 600 A T-body using an extension connector to span the additional 8  $\frac{5}{16}$ " (211 mm) distance and spiking location.

### Spiking aid separable cable joint

One leg of the stacked T-body cable joint is spiked/cut with a grounded guillotine-type cable cutter, near the T-body intersection. Once spiked and proven de-energized, the cable is re-prepped and a spiking-T with a lug extender is assembled and

reconnected to the stack. If this stack ever needs to be spiked again, the spiking-T provides a convenient place to spike with no additional cable prep required. Just replace the spiking-T and the lug extender for reduced outage and reduced cost.

The spiking aid adds a special interface with a replaceable appendage or link that provides a convenient place to spike the bus to assure that it is de-energized. This also ensures that all cables connected are de-energized. In the 2-, 3- and 4-way bus, an optional grounding attachment can be threaded onto the special interface for grounding during the outage. This ground also ensures that all connected cables are grounded. When the work is done and the ground removed, a new cap is installed.

#### Features

- Eliminates the need to spike the cable, thereby eliminating the need to splice or replace the cable
- Fully shielded, fully submersible, 100% peroxide-cured EPDM molded rubber
- Reusable components reduce inventory and other costs
- Includes integral capacitive test point
- Reduces outage time and outage cost









01







02

## 600 A spiking aid cable accessories

### Spiking aid separable cable joint

Image (not to scale)	Description	Voltage class (kV)	Cat. no.	Notes
	2-way insulated bus bar with test point and spiking aid	15/25	K656ISL	N1
	3-way insulated bus bar with test point and spiking aid	15/25	K656CYSL	N1
	4-way insulated bus bar with test point and spiking aid	15/25	K656CHSL	N1
	600 series spiking aid appendage	15/25, 35	K650SL	N2
	Grounding bar for spiking aid	15/25, 35	K650SLGB	–
	Assembly/disassembly tool	All	600YADT-2	N3
	Assembly/disassembly tool	All	600RRT-2	N3

### Repair and spiking aid T-body

Image (not to scale)	Description	Voltage class (kV)	Cat. no.	Notes
	600 series spiking elbow (with spiking contact, insulated plug, cap, stud, lug and cable adapter)	15/25	K656SELR-WOX	N4
	600 series extended elbow (with extended contact, insulated plug, cap, stud, lug and cable adapter)	15/25	K656ELR-WOX	N4
	600 series replacement elbow housing only without test point	15/25	K656BRLR	N5
	600 series replacement elbow housing only with test point	15/25	K656BRLR	N5
	600 series spiking elbow (with spiking contact)	15/25	K656BSELR	–
	600 series extended elbow (with extended contact)	15/25	K656BELR	–
	600 series spiking elbow (with spiking contact, insulating plug, cap, stud, lug and cable adapter)	15/25	K656SELR-WOX	N4
	600 series extended elbow (with extended contact, insulating plug, cap, stud, lug and cable adapter)	15/25	K656ELR-WOX	N4

N1. Insulated bus bar only.

N2. Replaceable spiking aid appendage for K656CHSL, K656CYSL and K656IS L and M series.

N3. Recommended for ease of assembly/disassembly of receptacles to bus. 600YADT-1 is lever drive and 600RRT is screw drive.

N4. Add suffix symbol from page 71 to include cable shield grounding kit and/or cable jacket sealing kit.

N5. Replacement elbow includes an I-adapter and straight receptacle, resulting in a net gain of 20".

Refer to the W and X tables on pages 80–81 for sizing to cable insulation diameter and conductor size. For cable shield adapters and jacket seals, see pages 70–71.

## 600 A separable cable joints

### 600 series separable cable joints

600 series separable cable joints are available in 2-, 3- and 4-way versions and include a capacitive test point as standard. Units are interchangeable, featuring bolted connections. Designs are compact and ideally suited for small vaults and manholes.

De-energized joints can be quickly and easily connected and disconnected using standard hand tools and equipment in accordance with accepted operating practices. Bus bars can be changed to add or remove cables from the joint.

Optional accessories include insulating and grounding caps and plugs that allow visible external separation, bypass, isolation, dead-ending, grounding and testing.

## Ratings overview

See pages 4–5 for complete information.

### Current ratings

(Prefixes: 650, K650, K655, K656 and 03700)

- 600 A continuous
- 25 kA sym., 10 cycles

### Voltage ratings

15/25 kV class (5 kV through 28 kV)

- 16.2 kV phase-to-ground
  - 28 kV phase-to-phase
  - 140 kV BIL
  - 45 kV AC withstand
  - 84 kV DC withstand
  - 21.5 kV corona extinction
- 35 kV class
- 21.1 kV phase-to-ground
  - 36.6 kV phase-to-phase
  - 150 kV BIL
  - 50 kV AC withstand
  - 103 kV DC withstand
  - 26 kV corona extinction

Note: Elastimold has increased the IEEE Standard Production and Design Test levels for 25 kV Class products to include 27 kV and 28 kV systems.

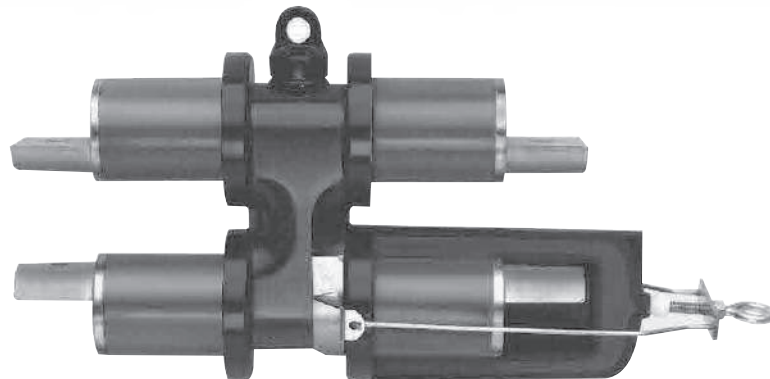

## 600 A separable cable joints

### 600 series separable cable joints

- 01 Separable joint (4-way)
- 02 Separable Wye-joint (3-way)
- 03 Separable straight joint (2-way)

### Separable cable joints – 600 series deadbreak

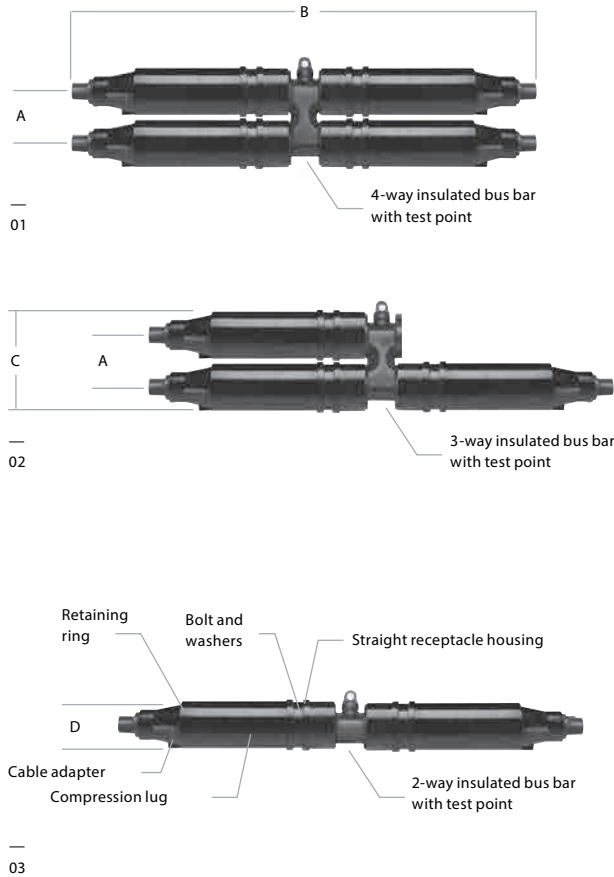



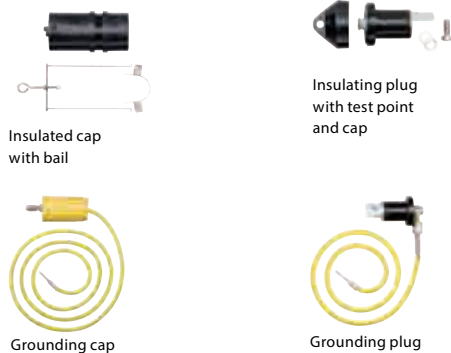







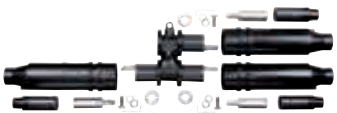

### Operating accessories

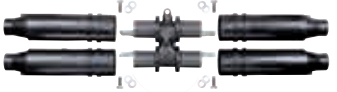

Note: The separable cable joints shown here use a special "Y" interface that may not be interchangeable with other 600 series interfaces.











Dimension	In.
A	4¼
B	37⅝
C	8⅝
D	3⅞

## 600 A separable cable joints

Image (not to scale)	Description	Voltage class (kV)	Cat. no.	Notes
	Separable straight joint pkg. (2-way) with test point	15/25	K656I-W0X	N1, 8, 12
		35	M656I-W0X Use tables W7 and X6	N1, 8, 12
	Basic housing pkg. straight joint with test point	15/25	K656I-HP	N2, 12
		35	M656I-HP	N2, 12
	Separable Wye joint pkg. (3-way) with test point	15/25	K656CY-W0X	N1, 8, 12
		35	M656CY-W0X Use tables W7 and X6	N1, 8, 12
	Basic housing pkg. Wye joint with test point	15/25	K656CY-HP	N2, 12
		35	M656CY-HP	N2, 12
	Separable "H" joint pkg. (4-way) with test point	15/25	K656CW0X	N1, 8, 12
		35	M656CW0X Use tables W7 and X6	N1, 8, 12
	Basic housing pkg. "H" joint with test point	15/25	K656CH-HP	N2, 12
		35	M656CH-HP	N2, 12
	2-way insulated bus bar with test point	15/25	K656I-BUS	N3, 12
		35	M656I-BUS	N3, 12
	3-way insulated bus bar with test point	15/25	K656CY-BUS	N3, 12
		35	M656CY-BUS	N3, 12
	4-way insulated bus bar with test point	15/25	K656CH-BUS	N3, 12
		35	M656CH-BUS	N3, 12
	Straight receptacle without test point	15/25	K655YSR-W0X	N4, 8
		35	M655YSR-W0X Use tables W7 and X6	N4, 8
	Direct test straight receptacle elbow	15/25	K655YDSR-W0X	N4, 8, 11
		35	M655YDSR-W0X Use tables W7 and X6	N4, 8, 11
	Direct test straight receptacle elbow with test point	15/25 kV	K656YDSR-W0X	N4, 8, 11
		35	M656YDSR-W0X Use tables W7 and X6	N4, 8, 11
	Straight receptacle housing only without test point	15/25	K655YBSR	N5, 10
		35	M655YBSR	N5, 10
	Straight receptacle housing only with test point	15/25	K656YBDSR	N5, 10
		35	M656YBDSR	N5, 10

## 600 A separable cable joints

### 600 A separable cable joints

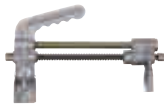
Image (not to scale)	Description	Voltage class (kV)	Cat. no.	Notes
	Insulated cap with bail	15/25	K655YDR	-
		35	M655YDR	-
	Bail only	15/25	650BA	-
		35	-	-
	Cable adapter	15/25	655CA-W	-
		35	Use table W7	-
	Adapter retaining ring	15/25	650ARR-X	-
		35	Use table X6	-
	Compression lug	15/25	03700X	N7
		35	03702X Use Table X6	N9
	600 Series straight receptacle size-sensitive kit (cable adapter, retaining ring and lug)	15/25	655CK-W0X-ARR	N8
		35	Use tables W7 and X6	
	Insulating plug with test point and cap	15/25	K650YBIP	-
		35	M650YBIP	-
	Grounding plug (4/0 AWG x 6' ground lead)	15/25	650YGP	-
		35		
	Grounding cap (4/0 AWG x 6' ground lead)	15/25	650GYDR	-
		35		
	Stainless steel bolt and washers	15/25	650BAW	-
		35		
	Assembly/disassembly tool	All	600YADT-2	N6
	Assembly/disassembly tool	All	600RRT-2	N6

N1. Complete joint packages consisting of: insulated bus bar, straight receptacle housings, retaining rings, cable size adapters, lugs, bolts and washers.

N2. Housing packages consisting of the following non-size sensitive components of the joint: insulated bus bar, straight receptacle housings, bolts and washers.

N3. Insulated bus bar only.

N4. Straight receptacle consisting of: straight receptacle housing, retaining ring, cable adapter, lug, bolt and washers.

N5. Straight receptacle housing consisting of: straight receptacle housing, bolt and washers.

N6. Recommended for ease of assembly/disassembly of receptacles to bus. 600YADT-1 is lever drive and 600RRT is screw drive.

N7. Aluminum lug for use on aluminum or copper conductors. DO NOT substitute threaded 03600X lug.

N8. Add suffix symbol from page 71 to include cable shield grounding kit and/or cable jacket sealing kit.

N9. Copper lug for use with COPPER CONDUCTOR ONLY. DO NOT substitute threaded 03602X lug.

N10. Available without the bolt and washers by adding "N" to the part number.

N11. Direct test connectors, along with a 200TC-X series meter adapter, a properly rated voltage meter and hot-line stick, provides a means for direct conductor voltage testing. See page 24 for meter adapters.

N12. Available with spiking aid option: K656CHSL, K656CYSL and K656IS L and M series.

Refer to the W and X tables on pages 80–81 for sizing to cable insulation diameter and conductor size. For cable shield adapters and jacket seals, see pages 70–71.



## Multi-point junctions

### Molded multi-point junctions

01 J6-622226-25

02 J6-662266-25-SV

Elastimold® multi-point junctions are available in 2-, 3-, 4-, 5- or 6-point configurations with 15, 25/28 or 35 kV ratings. Units feature modular design flexibility, allowing selection of any combination of 200 A deepwell or 600 A bushing interfaces located on standard 4" or optional 6 ½" centers. The 6 ½" center spacing is especially well suited for distributed switchgear applications, including fused elbow, MVI fault interrupter, MVS switch, etc.

Designs incorporate lightweight, damage-resistant, EPDM molded rubber construction and corrosion-resistant 304 stainless steel mounting brackets. Junctions are maintenance free, fully shielded, deadfront and submersible. Units are ideally suited for subsurface, padmount, indoor and outdoor vault applications.

Elastimold multi-point junctions provide a convenient method for connecting, looping and tapping of 200 A and 600 A elbows and other accessories at a common location where utilization of space, cable training, flexibility and operability are important.

### Features

- 15/25/35 kV, 200/600 A molded multipoint junctions
- Fully shielded, fully submersible molded rubber housing
- Uses 304 stainless steel for brackets to prevent rusting and corrosion
- Provides mating for Elastimold elbow connectors, both 600 A and 200 A
- Increases flexibility and operational ability by saving space in crucial areas
- Optional bails available for 200 A deadbreak application



01

### Ratings overview

See pages 4–5 for complete information

#### Current ratings

- 600 A continuous
- 25 kA sym., 10 cycles

Or with 200-amp bushing well versions

- 200 A continuous
- 10 kA sym., 10 cycles

#### Voltage ratings

15 kV class

- 8.3 kV phase-to-ground
- 95 kV BIL
- 34 kV AC withstand
- 53 kV DC withstand
- 11 kV corona extinction

25/28 kV class

- 16.2 kV phase-to-ground
- 140 kV BIL
- 45 kV AC withstand
- 84 kV DC withstand
- 21.5 kV corona extinction

35 kV class

- 21.1 kV phase-to-ground
- 150 kV BIL
- 50 kV AC withstand
- 103 kV DC withstand
- 26 kV corona extinction



02

# Multi-point junctions

## Molded multi-point junctions

01 Figure 1: Multi-point junctions with 4" interface spacings.

02 Figure 2: Multi-point junctions with 6 1/2" interface spacings.

### Dimensional information

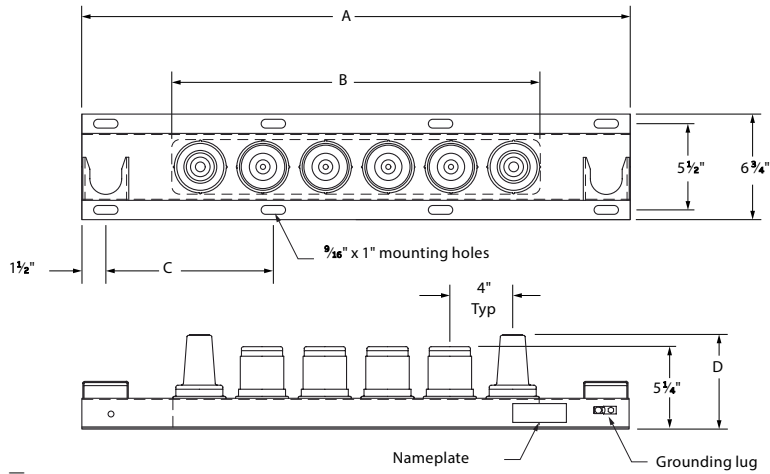

01

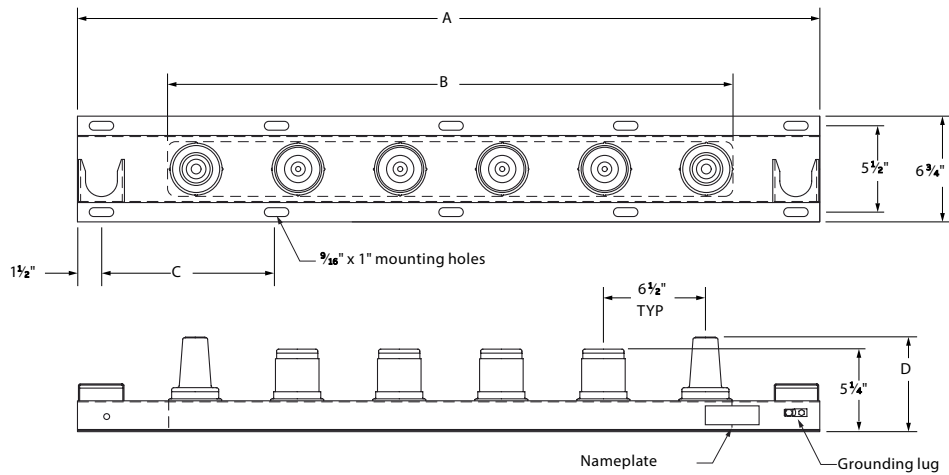

02

Type of junction	Figure 1				Figure 2			
	Dimensions (in.)			Number of mounting holes	Dimensions (in.)			Number of mounting holes
A	B	C	A		B	C		
J2	15	7 1/2	6	6	19 1/2	10	8 1/4	6
J3	19	11 1/2	8	6	26	16 1/2	11 1/2	6
J4	24	15 1/2	10	6	32 1/2	23	9 1/4	8
J5	27	19 1/2	12	6	39	29 1/2	12	8
J6	31	23 1/2	9 3/8	8	45 1/2	36	8 1/4	10

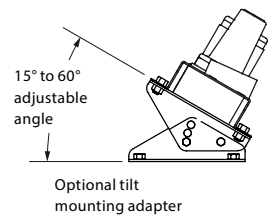





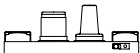

## Multi-point junctions

### Molded multi-point junctions

Elastimold<sup>®</sup> multi-point junctions feature modular design flexibility that permits the specifier to determine the positions of the bushing interfaces and bushing well positions.

Base catalog numbers

Image (not to scale)	Description	Voltage class (kV)	Cat. no.		Notes
			4" spacing	6½" spacing	
	2-point junction	15	J2 - ____ - 15	J2 - ____ - 15-SV	N1, 2
		25/28	J2 - ____ - 25	J2 - ____ - 25-SV	
		35	J2 - ____ - 35	J2 - ____ - 35-SV	
	3-point junction	15	J3 - _____ - 15	J3 - _____ - 15-SV	N1, 2
		25/28	J3 - _____ - 25	J3 - _____ - 25-SV	
		35	J3 - _____ - 35	J3 - _____ - 35-SV	
	4-point junction	15	J4 - _____ - 15	J4 - _____ - 15-SV	N1, 2
		25/28	J4 - _____ - 25	J4 - _____ - 25-SV	
		35	J4 - _____ - 35	J4 - _____ - 35-SV	
	5-point junction	15	J5 - _____ - 15	J5 - _____ - 15-SV	N1, 2
		25/28	J5 - _____ - 25	J5 - _____ - 25-SV	
		35	J5 - _____ - 35	J5 - _____ - 35-SV	
	6-point junction	15	J6 - _____ - 15	J6 - _____ - 15-SV	N1, 2
		25/28	J6 - _____ - 25	J6 - _____ - 25-SV	
		35	J6 - _____ - 35	J6 - _____ - 35-SV	
	5-point junction	25/28	J5 - 66666 - 25CU	-	N2, 3
		35	J5 - 66666 - 35CU		
	6-point junction	25/28	J6 - 666666 - 25CU	-	N2, 3
		35	J6 - 666666 - 35CU		

N1. The 6 ½" wide spacing is necessary if the junction is to be used to connect with a single-phase MVS molded vacuum switch or MVI molded vacuum interrupter.

N2. Also available with a shorter bracket by reducing the number of parking stands; see R, L, N in options.

N3. Copper conductor for 900 A rating. Use suffix "CU" at the end of the catalog number.

## Multi-point junctions

### Ordering information

To specify and order Elastimold multi-point junctions: Use Table 1 to construct a catalog number describing the required junction.

#### Ordering example A

To order a 4-point, 15 kV junction with 4" spacings and 600 series interfaces on the outside ways and 200 A wells on the inside ways, specify catalog number J4-6226-15.

#### Ordering example B

To order a 6-point, 25/28 kV junction with 6 1/2" spacings and 600 series interfaces on ways 1, 3, 4 and 6 and 200 A wells on the ways 2 and 5, specify catalog number J6-626626-25-SV.

Table 1. Catalog number construction

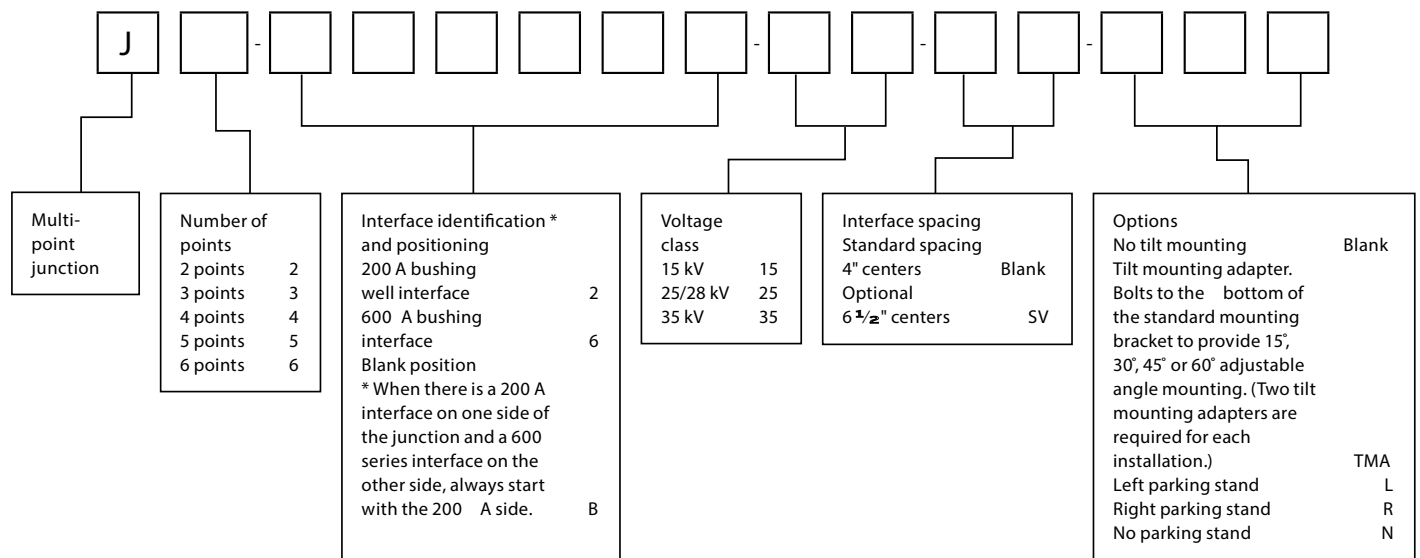

## ComboT integral separable connectors

01 ComboT CETP installed.

02 ComboT CCP installed.

ComboT provides the shortest elbow stack height and the most reliable assembly in the industry.

The shortest stack height in the industry – Works in smaller cabinets and installs in tighter spaces

- Shortest stack height – Each combination elbow/connecting plug reduces stack height 2.67"
- Eliminates blind assembly – Simple connection system reduces the chance of cross threading and is easier to line up and install
- Fewer interfaces and reduced inventory – Combination elbow reducing taps, connecting and bushing well plugs

- Installs with your standard assembly tools – unique conductive component and uses standard 600 or 900 series stud
- Ensures proper installation torque – Internal hex broach
- IEEE 386 color-coded PBT interfaces – Red for 15 kV reducing tap and blue for 25 kV reducing tap; provide better visibility and seating indication, plus reduces sticking
- 25 kV reducing tap with vents – prevents partial-vacuum flashover



01

02

## ComboT integral separable connectors

### Ratings

Simple design, simple assembly

The 15 kV CETP and 15/25 kV CCP simple design makes assembly quick and easy, using a standard  $\frac{5}{8}$ "-11 stud that is threaded into the equipment bushing. The hollow bore of the ComboT allows visual validation that the compression lug is positioned properly before the snuffer/bus is inserted and tightened. If preferred, the stud may be first threaded into the snuffer/bus.

Again, the hollow bore of the ComboT allows visual validation that the compression lug is correctly positioned before proceeding. This is all accomplished with the same parts in a ComboT kit. There is no need to choose "male fastener" or "female fastener" when ordering.

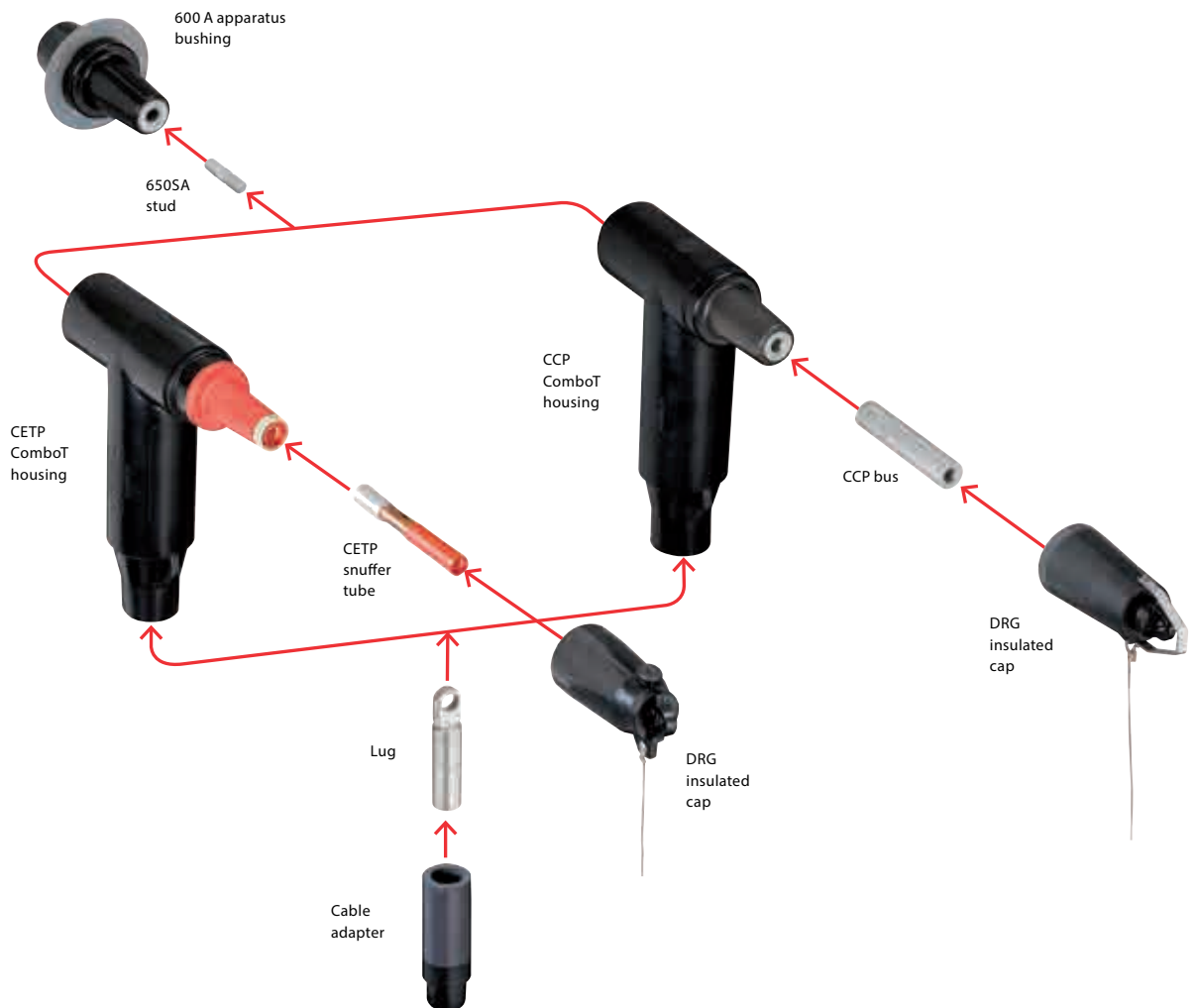



Ratings





Base catalog series	Deadbreak with loadbreak reducing tap							
	655/656CETP series 600 A deadbreak		675/676CETP series 900 A deadbreak		K655/K656CETP series 600 A deadbreak		K675/K676CETP series 900 A deadbreak	
Voltage class (kV)	15	-	15	-	25	-	25	-
Max. phase-to-ground operating voltage (kV)	8.3	-	8.3	-	15.2	-	15.2	-
Max. phase-to-phase operating voltage (kV)	14.4	-	14.4	-	26.3	-	26.3	-
BIL – Impulse withstand (1.2 x 50 microsecond wave) (kV)	95	-	95	-	125	-	125	-
AC – One-minute withstand voltage (kV)	34	-	34	-	40	-	40	-
DC – 15-minute withstand voltage (kV)	53	-	53	-	78	-	78	-
Corona extinction level @ 3.0 pC sensitivity (kV)	11	-	11	-	19	-	19	-
Interface/connection	600 A DB	200 A LB	900 A DB	200 A LB	600 A DB	200 A LB	900 A DB	200 A LB
Continuous current (A)	600	200	900	200	600	200	900	200
Loadmake/loadbreak switching current (A)	-	200	-	200	-	200	-	200
Symmetrical momentary current – 10 cycle (kA)	25	10	25	10	25	10	25	10
Symmetrical one-time fault close current – 10 cycle (kA)	-	10	-	10	-	10	-	10
Symmetrical momentary current – 3 second (kA)	10	3.5	10	3.5	10	3.5	10	3.5

Ratings

Base catalog series	Deadbreak with connecting plug		Deadbreak with bushing well	
	K655K656 CCP series 600 A deadbreak	K675K676 CCP series 900 A deadbreak	K655K656 CBW series 600 A deadbreak	K675K676 CBW series 900 A deadbreak
Voltage class (kV)	15/25/28	15/25/28	15/25/28	15/25/28
Max. phase-to-ground operating voltage (kV)	16.2	16.2	16.2	16.2
Max. phase-to-phase operating voltage (kV)	28.0	28.0	28.0	28.0
BIL – Impulse withstand (1.2 x 50 microsecond wave) (kV)	140	140	140	140
AC – One-minute withstand voltage (kV)	45	45	45	45
DC – 15-minute withstand voltage (kV)	84	84	84	84
Corona extinction level @ 3.0 pC sensitivity (kV)	21.5	21.5	21.5	21.5
Continuous current (A)	600	900	600	900
Symmetrical momentary current – 10 cycle (kA)	25	25	25	25
Symmetrical momentary current – 3 second (kA)	10	10	10	10

## ComboT integral separable connectors

### ComboT integral separable connectors









































Description	kV class	Test point	Continuous current, amps	Connector: universal aluminum, copper or bi-metal	Cat. no.	Notes	Basic ComboT elbow with bus and stud	
								Kit not to scale
ComboT elbow/ reducing tap plug	15	No	600	U-AL	655BCETP	–		(No test point; aluminum shown)
			900	CU	675BCETP	1		
			900	BM	675BCETP	1		
		Yes	600	U-AL	656BCETP	–		
			900	CU	676BCETP	1		
			900	BM	676BCETP	1		
ComboT elbow/ reducing tap plug	25	No	600	U-AL	K655BCETP	–		(Test point; aluminum shown)
			900	CU	K675BCETP	1		
			900	BM	K675BCETP	1		
		Yes	600	U-AL	K656BCETP	–		
			900	CU	K676BCETP	1		
			900	BM	K676BCETP	1		
ComboT elbow/ connecting plug	15/25	No	600	U-AL	K655BCCP	–		(No test point; aluminum shown)
			900	CU	K675BCCP	1		
			900	BM	K675BCCP	1		
		Yes	600	U-AL	K656BCCP	–		
			900	CU	K676BCCP	1		
			900	BM	K676BCCP	1		
ComboT elbow/ bushing well	15/25	No	600	U-AL	K655BCBW	–		(Test point; aluminum shown)
			900	CU	K675BCBW	1		
			900	BM	K675BCBW	1		
		Yes	600	U-AL	K656BCBW	–		
			900	CU	K676BCBW	1		
			900	BM	K676BCBW	1		

Notes: 1. 900 A continuous is based on an all-copper system: bushing, stud, tang of the lug, contact of the plug and a cable of equal rating.

2. W and X vary with medium-voltage cable being used, with W based on the insulation diameter and X on the conductor size and construction. See page 58 for specifics.



ComboT integral separable connectors

ComboT Elbow with bus, stud, cable adapter and lug kit			ComboT elbow with bus, stud, cable adapter, lug and insulated cap kit		
Cat. no.	Notes	Kit not to scale	Cat. no.	Notes	Kit not to scale
655CETPW0X	2	(No test point; aluminum shown)	655CETPW0XDRG	2	(No test point; aluminum shown)
675CETPW2X	1, 2		675CETPW2XDRG	1, 2	
675CETPW5X	1, 2		675CETPW5XDRG	1, 2	
656CETPW0X	2		656CETPW0XDRG	2	
676CETPW2X	1, 2		676CETPW2XDRG	1, 2	
676CETPW5X	1, 2		676CETPW5XDRG	1, 2	
k655CETPW0X	2	(Test point; aluminum shown)	K655CETPW0XDRG	2	(Test point; aluminum shown)
K675CETPW2X	1, 2		K675CETPW2XDRG	1, 2	
K675CETPW5X	1, 2		K675CETPW5XDRG	1, 2	
K656CETPW0X	2		K656CETPW0XDRG	2	
K676CETPW2X	1, 2		K676CETPW2XDRG	1, 2	
K676CETPW5X	1, 2		K676CETPW5XDRG	1, 2	
K655CCPW0X	2	(No test point; aluminum shown)	K655CCPW0XDRG	2	(No test point; aluminum shown)
K675CCPW2X	1, 2		K675CCPW2XDRG	1, 2	
K675CCPW5X	1, 2		K675CCPW5XDRG	1, 2	
K656CCPW0X	2		K656CCPW0XDRG	2	
K676CCPW2X	1, 2		K676CCPW2XDRG	1, 2	
K676CCPW5X	1, 2		K676CCPW5XDRG	1, 2	
K655CBWW0X	2	(Test point; aluminum shown)	K655CBWW0XBWP	2	(Test point; aluminum shown)
K675CBWW2X	1, 2		K675CBWW2XBWP	1, 2	
K675CBWW5X	1, 2		K675CBWW5XBWP	1, 2	
K656CBWW0X	2		K656CBWW0XBWP	2	
K676CBWW2X	1, 2		K676CBWW2XBWP	1, 2	
K676CBWW5X	1, 2		K676CBWW5XBWP	1, 2	

Notes: 1. 900 A continuous is based on an all-copper system: bushing, stud, tang of the lug, contact of the plug and a cable of equal rating.  
 2. W and X vary with medium-voltage cable being used, with W based on the insulation diameter and X on the conductor size and construction. See page 58 for specifics.

# ComboT integral separable connectors

## Ordering information

The following diagram shows how to construct a catalog number for a ComboT.

Indicates field that must be filled in to complete the catalog number.

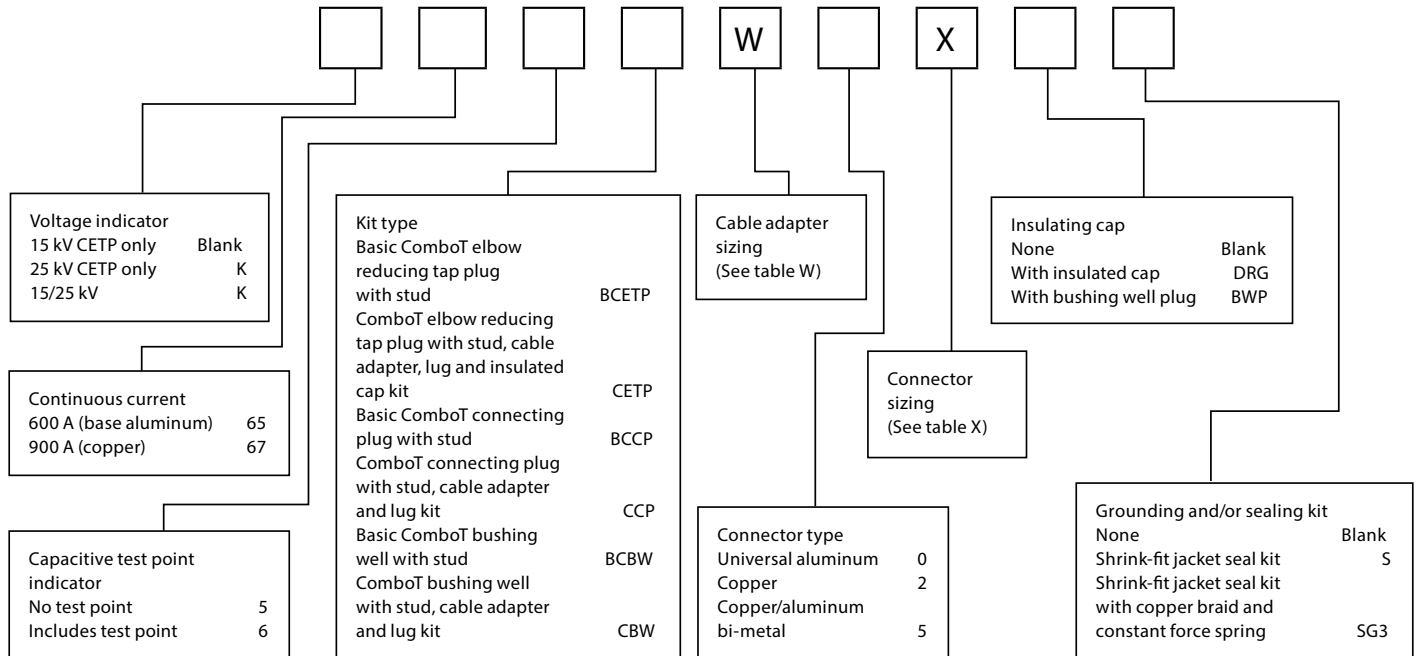

Table W – Cable adapter sizing

Cable insulation dia. range		mm		Symbol for W
Inches		Min.	Max.	
Min.	Max.	Min.	Max.	
0.640	0.820	16.3	20.8	F
0.760	0.950	19.3	24.1	G
0.850	1.050	21.6	26.7	H
0.980	1.180	24.9	30.0	J
1.090	1.310	27.7	33.3	K
1.180	1.465	30.0	37.2	L
1.280	1.430	32.5	36.3	LM
1.370	1.630	34.8	41.4	M
1.550	1.780	38.5	45.2	N
1.725	1.935	43.8	49.1	P

Table X – Connector sizing

AWG or kcmil		mm <sup>2</sup>		X code
Stranded/compressed	Solid/compact	Compact only		
–	2	25		210
2	1	35		220
1	1/0	50		230
1/0	2/0	–		240
2/0	3/0	70		250
3/0	4/0	95		260
4/0	250	125		270
250	300	–		280
300	350	150		290
350	400	185		300
400	450	240		310
450	500	–		320
500	600	300		330
650	750	400		360
750	900	–		380
900	1000	500		400
1000	–	–		410
–	1250	630		420
1250	–	–		440

## Permanent distribution cable joints

### PCJ™ power cable joints

PCJ power cable joints use permanently crimped connectors. PCJ housings are fully insulated, shielded and sealed for direct-burial, vault, submersible and other severe service applications. Units have been designed and tested per IEEE Standard 404 to ensure system-matched performance and ratings equal to the cable to which the splice will be installed.

PCJ power cable joints are available in two styles:  
Style 1 uses a single-piece housing that is sized to accommodate a specific range of cable. Style 1 units are ideally suited for straight splicing of the same or similar cable.

Style 2 designs incorporate a universal housing with separate cable adapters to allow transition splices of different types and sizes of cable.

### Electrical ratings summary

The follow ratings summary is based on IEEE 404 and applies to all Elastimold PCJ power cable joints.

#### Voltage

- A. 15 kV class (8.7 kV phase-to-ground)
- B. 25 kV class (14.4 kV phase-to-ground)
- C. 35 kV class (20.2 kV phase-to-ground)
- Impulse withstand: A = 110 kV, B = 150 kV, C = 200 kV BIL, 1.2 x 50 microsecond wave
- Corona extinction voltage: A = 13 kV, B = 22 kV, C = 30 kV minimum, 3 pC sensitivity
- DC withstand: During installation, A = 56 kV, B = 80 kV, C = 100 kV
- DC withstand: After installation and in service for the first 5 years, A = 18 kV, B = 25 kV, C = 31 kV for XLPE insulated cables and A = 45 kV, B = 64 kV, C = 80 kV for EPR insulated cables (reference AEIC CS6 and CS8, Section L.2)

#### Current

Continuous rating equal to the rating of the cable  
Short-time rating equal to the rating of the cable up to 35 kA

#### Shield design

- Meets IEEE 592 for exposed semiconducting shields on premolded high voltage cable joints and separable insulated connectors

Production tests include 100% tests of the premolded joints to ensure:

- Corona extinction voltage: A = 13 kV, B = 22 kV, C = 30 kV minimum, 3 pC sensitivity
- AC withstand: A = 35 kV, B = 52 kV, C = 69 kV, 60 Hz, 1 minute

Design tests on production joints demonstrate compliance with IEEE 404 including:

- Corona extinction voltage: A = 13.0 kV, B = 22.0 kV, C = 30.0 kV minimum, 3 pC sensitivity
- AC withstand: A = 35 kV, B = 52 kV, C = 69 kV, 60 Hz, 1 minute
- DC withstand: A = 75 kV, B = 105 kV, C = 140 kV negative polarity, 15 minutes
- Impulse withstand (BIL): A = 110 kV, B = 150 kV, C = 200 kV, 10 positive and 10 negative, 1.2 x 50 microsecond wave, at conductor temperatures of 20 °C and 130 °C, nominal
- Short-time current: Magnitude equal to cable up to 35 kA
- Cyclic aging: 30 days at A = 26 kV, B = 43 kV, C = 61 kV AC continuous, load current for 8 hours per day, providing 130 °C conductor temperature; joints then subjected to A = 31 kV, B = 50 kV, C = 71 kV for 5 hours followed by A = 39 kV, B = 65 kV, C = 91 kV for 5 min
- Load cycle: Connectors meet requirements of ANSI C119.4, Class A and Class 3 ratings

Permanent distribution cable joints  
 PCJ™ power cable joints

PCJ style 1

With single-piece housing

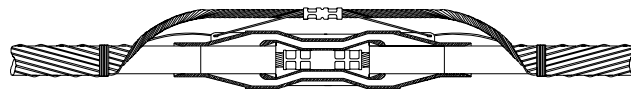

PCJ style 2

With universal housing and separate cable adapters that can be varied with the cable application

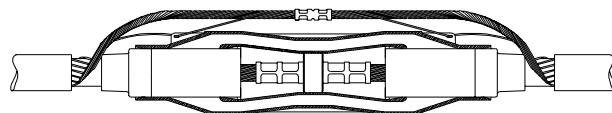
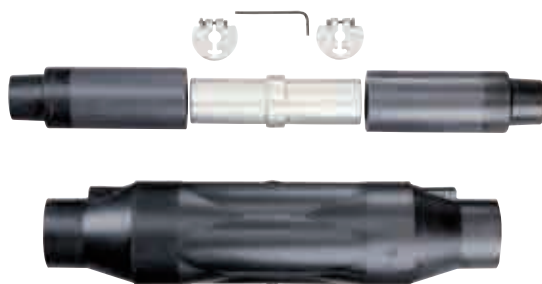

Ordering information

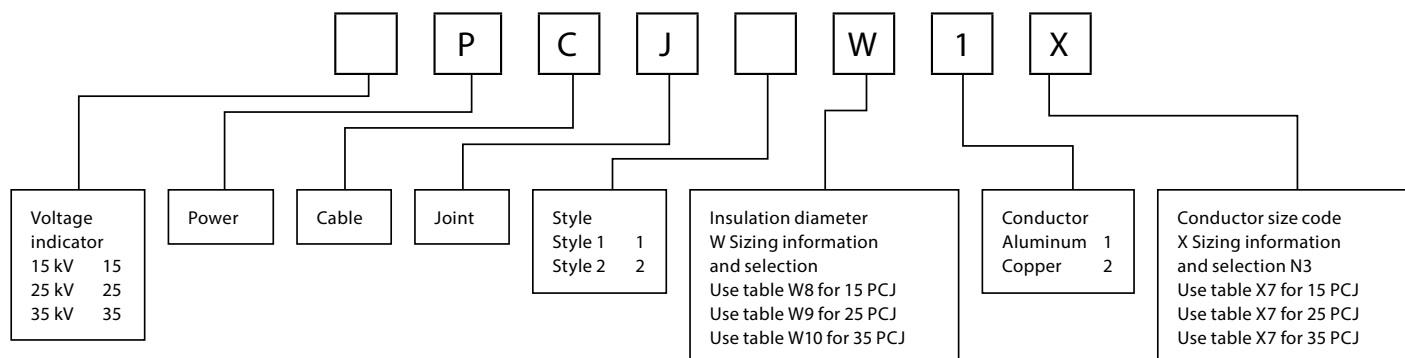

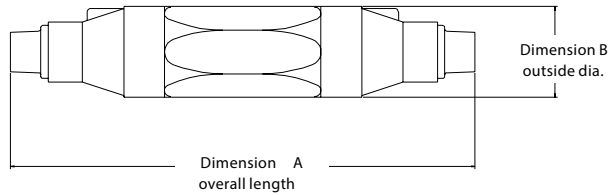

Dimensional data

Style 1 Cat. no.	A inches	B inches
15PCJ1FX	10 1/4	1 3/4
15PCJ1GX	10 1/4	1 3/4
25PCJ1GX	14 3/8	2 7/16
15/25/35PCJ1HX	14 3/8	2 7/16
15/25/35PCJ1JX	14 3/8	2 7/16
15/25/35PCJ1KX	14 3/8	2 25/32
15/25/35PCJ1LX	14 3/8	2 25/32
15/25PCJ1LMX	14 3/8	2 25/32
15/25/35PCJ1MX	14 3/8	2 25/32
15/25/35PCJ1NX	15 3/4	3 3/16
15/25/35PCJ1PX	15 3/4	3 3/16
15/25/35PCJ1QX	15 3/4	3 3/16

Dimensional data

Style 2 Cat. no.	A inches	B inches
15PCJ2FX	16 3/8	2 25/32
15/25PCJ2GX	16 3/8	2 25/32
15/25/35PCJ2HX	16 3/8	2 25/32
15/25/35PCJ2JX	16 3/8	2 25/32
15/25/35PCJ2KX	21	3 3/4
15/25/35PCJ2LX	21	3 3/4
15/25/35PCJ2MX	21	3 3/4
15/25/35PCJ2NX	21	3 3/4
15/25/35PCJ2PX	21	3 3/4
15/25/35PCJ2QX	21	3 3/4

PCJ power cable joint

Description	Voltage class (kV)	Cat. no.	Notes
Power cable joint Style 1	15	15PCJ1W1X	N1
	15	15PCJ1W2X	N2
	25	25PCJ1W1X	N1
	25	25PCJ1W2X	N2
	35	35PCJ1W1X	N1
	35	35PCJ1W2X	N2
Power cable joint Style 2	15	15PCJ2W1X	N1
	15	15PCJ2W2X	N2
	25	25PCJ2W1X	N1
	25	25PCJ2W2X	N2
	35	35PCJ2W1X	N1
	35	35PCJ2W2X	N2



N1. Kit includes aluminum compression connector suitable for splicing aluminum conductor to aluminum conductor or aluminum conductor to copper conductor. An all-copper connector is required for copper-to-copper connections.  
 N2. Kit includes copper compression connector suitable for splicing copper conductors to copper conductor only. DO NOT use copper connectors on aluminum conductors.  
 N3. When constructing a catalog number for a transition (two different-size cables) joint, list the larger connector first and the smaller connector second.

Refer to the W and X tables on pages 80–81 for sizing to cable insulation diameter and conductor size. For cable shield adapters and jacket seals, see pages 70–71.

## Distribution shrink-fit terminations

### Ranger2™ terminations

#### Ranger2 termination connector options

	Type	Material	Conductor	Conductor size	Connector prefix*
	Stem compression connector	Aluminum	Aluminum or copper	#2-4/0 (34-107)	T0
		Aluminum	Aluminum only	#2-4/0 (34-107)	T1
	One-hole spade connector	Tinned aluminum	Aluminum or copper	#2-500 (34-253)	H0
	Two-hole spade connector	Tinned aluminum	Aluminum or copper	#2-1250 (34-633)	N0
		Tinned copper	Copper	#2-1250 (34-633)	N2



\* See page 71 for conductor code.

#### Optional cable support brackets

	Type	Cable range (overall O.D.)	Stainless steel	
			Cat. no.	Suffix number
	Single clamp	0.80"-1.25" (20-32 mm)	JB-1	B1
	Single clamp	1.10"-1.50" (28-38 mm)	JB-2	B2
	Double clamp	1.45"-1.95" (37-50 mm)	JB-3	B3
	Double clamp	1.80"-2.40" (45-61 mm)	JB-4	B4

#### Add-on grounding kits

Convert a jacketed concentric neutral "J" kit to an "M" or "L" shield kit

	Cat. no.	Type	Size	Use with series
	GMA	Tape shield/wire shield/unishield	A	R2IT15J1, R2IT15J2, R2T15J1, R2T15J2, R2T28J2, R2T35J2
	GMB	Tape shield/wire shield/unishield	B	R2IT15J4, R2T15J4, R2T28J4, R2T35J4
	GLA	LC shield/wire over tape shield	A	R2IT15J1, R2IT15J2, R2T15J1, R2T15J2, R2T28J2, R2T35J2
	GLB	LC shield/wire over tape shield	B	R2IT15J4, R2T15J4, R2T28J4, R2T35J4

# Distribution shrink-fit terminations

## Ranger2™ terminations

### Ordering information for Ranger2 terminations

Ranger2 terminations may be ordered in components or as complete kits by following the steps outlined and using the model below to develop the catalog number for your application. Contact your local ABB sales representative for special requirements.

Indicates field that must be filled in to complete order. Note: Availability of selected configuration will be verified at quotation time.

The following diagram shows how to construct a catalog number for a Ranger2 termination.

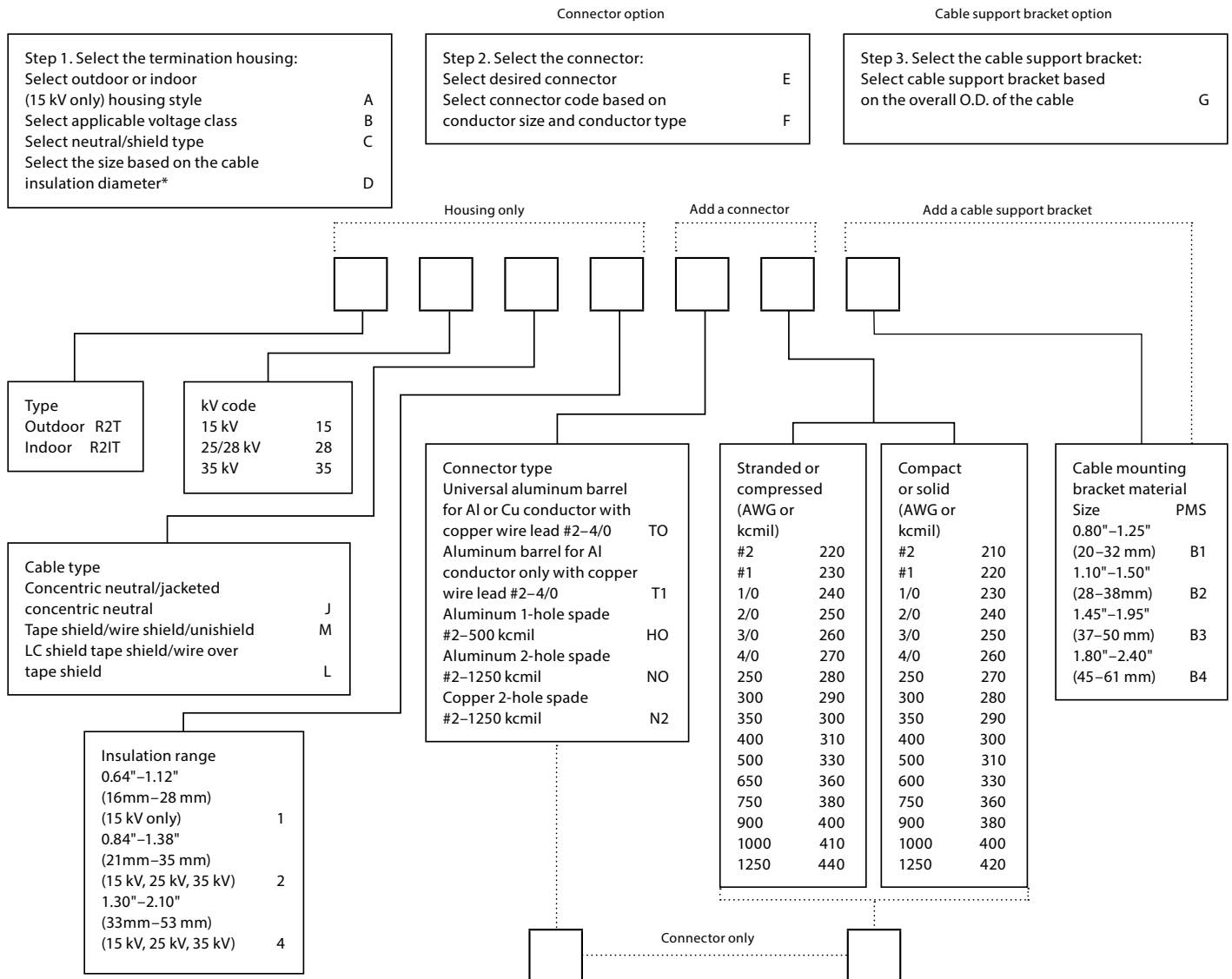







\* To help in selecting the proper terminator, ICEA and AIEC standard dimensions for XLP and EPR cables are on pages 76-78.  
 \*\* In 28 kV, the connector type "NO" is only for insulation range 2 and 4.

## Equipment bushings

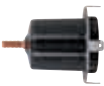
The ABB Elastimold® brand offers a complete line of 200 A bushing well and 600 A series apparatus bushings for use on transformers, switchgear and other equipment applications. The bushings incorporate IEEE 386 standard interfaces (shown on 6) and are constructed of molded epoxy with stainless steel flanges for mounting by welding or

gasketed clamp. Bushings are available for use on air, oil or SF6 insulated equipment. Units are rated for submersible, padmount, indoor, outdoor and other applications. Options include hold-down bail tabs and replaceable studs for 200-amp deepwell bushings.

### Equipment bushings

Image (not to scale)	Description	Voltage class (kV)	Cat. no.	Bushing shank length (in.)	Notes
	Short shank well with bail tabs and non-replaceable well stud	15/25	K1601PC-S1	2 <sup>3</sup> / <sub>4</sub>	N3, 7, 12
		35	L1601PC-S1		N3, 7, 12, 16
	Short shank well with bail tabs and replaceable well stud	15/25	K1601PC-S1-R	2 <sup>3</sup> / <sub>4</sub>	N1, 3, 7, 12
		35	L1601PC-S1-R		N1, 3, 7, 12, 16
	Short shank well without bail tabs and non-replaceable well stud	15/25	K1601PC-S2	2 <sup>3</sup> / <sub>4</sub>	N3, 7, 12, 15
		35	L1601PC-S2		N3, 7, 12, 15, 16
Short shank well without bail tabs and with replaceable well stud	15/25	K1601PC-S2-R	2 <sup>3</sup> / <sub>4</sub>	N1, 3, 7, 12, 15	
	35	L1601PC-S2-R		N1, 3, 7, 12, 15, 16	
	Long shank well with bail tabs and non-replaceable well stud	15/25	K1601PC-T1	9 <sup>1</sup> / <sub>4</sub>	N3, 7, 12
		35	L1601PC-T1		N3, 7, 12, 16
	Long shank well with bail tabs and with replaceable well stud	15/25	K1601PC-T1-R	9 <sup>1</sup> / <sub>4</sub>	N1, 3, 7, 12
		35	L1601PC-T1-R		N1, 3, 7, 12, 16
	Long shank well without bail tabs and with non-replaceable well stud	15/25	K1601PC-T2	9 <sup>1</sup> / <sub>4</sub>	N3, 7, 12, 15
		35	L1601PC-T2		N3, 7, 12, 15, 16
Long shank well without bail tabs and with replaceable well stud	15/25	K1601PC-T2-R	9 <sup>1</sup> / <sub>4</sub>	N1, 3, 7, 12, 15	
	35	L1601PC-T2-R		N1, 3, 7, 12, 15, 16	
	200 A deadbreak bushing	15/25	K180S4	2 <sup>9</sup> / <sub>16</sub>	N3, 7, 11
	200 A deadbreak bushing	15/25	K180T4	7 <sup>11</sup> / <sub>32</sub>	N3, 7, 11
	200 A deadbreak bushing	15/25	K180C4	9 <sup>1</sup> / <sub>4</sub>	N3, 7, 11
	600 A short shank bushing without stud	15/25	K650S1	2 <sup>15</sup> / <sub>16</sub>	N2, 5, 7, 12, 13, 15, 18, 19
	900 A Cu short shank bushing without stud	15/25	K675S1		N3, 5, 7, 12, 13, 15, 18, 19
	600 A short shank bushing without stud	35	750S1		N2, 5, 7, 12, 14, 15, 16, 18, 19
	600 A long shank bushing without stud	15/25	K650T1	8 <sup>9</sup> / <sub>16</sub>	N2, 5, 7, 12, 13, 15, 18
	900 A Cu long shank bushing without stud	15/25	K675T1	8 <sup>9</sup> / <sub>16</sub>	N3, 5, 7, 12, 13, 15, 18
	600 A long shank bushing without stud	35	750T1	8 <sup>9</sup> / <sub>16</sub>	N2, 5, 7, 12, 14, 15, 16, 18
	600 A 12" long shank bushing without stud	35	750L12	12	N2, 5, 7, 12, 14, 15, 16, 18
	600 A in-air long shank bushing without stud	15/25	K650TBC	8 <sup>9</sup> / <sub>16</sub>	N2, 4, 7, 6, 12
	900 A Cu in-air long shank bush without stud	15/25	K675TBC	-	N3, 5, 7, 6, 12
	Boot and collars for K600T1 to use in air	15/25	600BC	-	N6
600 A bushing and gasket kit	15/25	600CK	-	-	
	35	600CK	-	-	
200 A bushing clamp and gasket kit – 3 holes	15/25	K1601PC-S2-CK3H	-	17	
	35	L1601PC-S2-CK3H	-	17	
200 A bushing clamp and gasket kit – 4 holes	15/25	K1601PC-S2-CK4H	-	17	
	35	L1601PC-S2-CK4H	-	17	

N1. Replacement stud available separately. Specify 1601RS.

N2. Equipped with standard aluminum conductor rod.

N3. Equipped with copper conductor rod.

N4. Includes 3/4"-11 threaded stud at elbow end.

N5. Includes 3/8"-11 threaded hole at elbow end.

N6. Provides increased creep and strike.

N7. Includes shipping cap.

N11. Parking stands for 200 A deadbreak applications are available as separate items. Specify 151PS.

N12. Parking stands for 200 A loadbreak and 600 A deadbreak applications are available as separate items. Specify 160PS.

N13. Aluminum stud available separately. Specify 650SA.

N14. Aluminum stud available separately. Specify 750SA.

N15. Available as a kit with clamp and gasket adding suffix "CK".

N16. Available for 35 kV with 200 kV BIL adding suffix "-200".

N17. For use on bushing well without bail tabs only.

N18. Add suffix "-CLB" for flange with stud clearance for clamping.

N19. Notched flange for bolted mounting add -NF



## Elastimold fuse housings ordering information

The following diagram shows how to construct a catalog number for a fuse housing:

Indicates field that must be filled in to complete the catalog number.

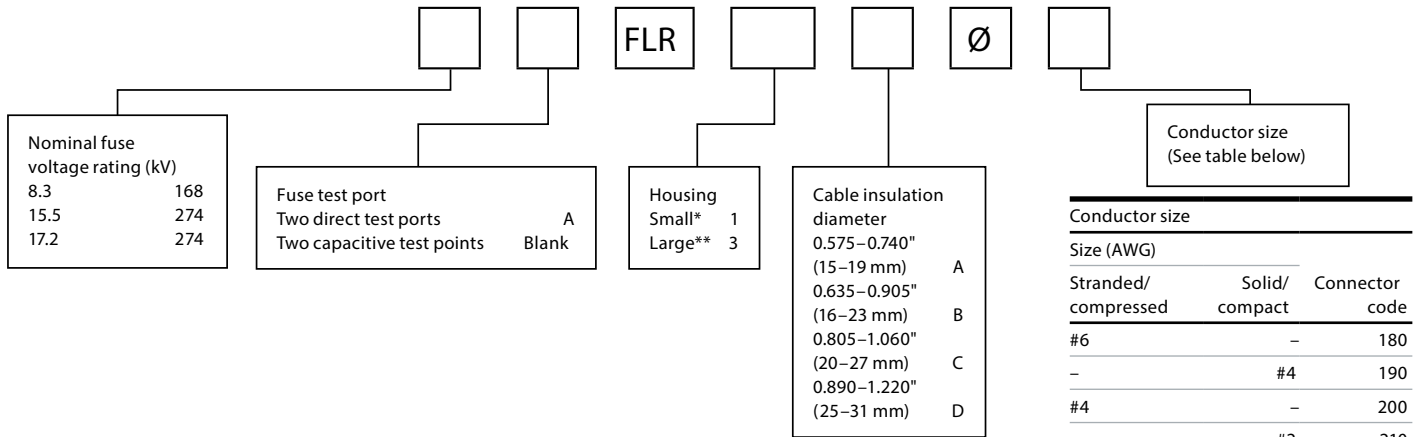

\*Small housing is used with 8.3 kV (3–45 A) and 15.5 kV (6–20 A) rated fuses.  
 \*\*Large housing is used with 8.3 kV (65 A and 80 A) and 17.2 kV (3–45 A) rated fuses.

- 01 168FLR1
- 02 274FLR1
- 03 168FLR3 A = 8 7/8" (225 mm)
- 274FLR3 A = 9 3/4" (235 mm)

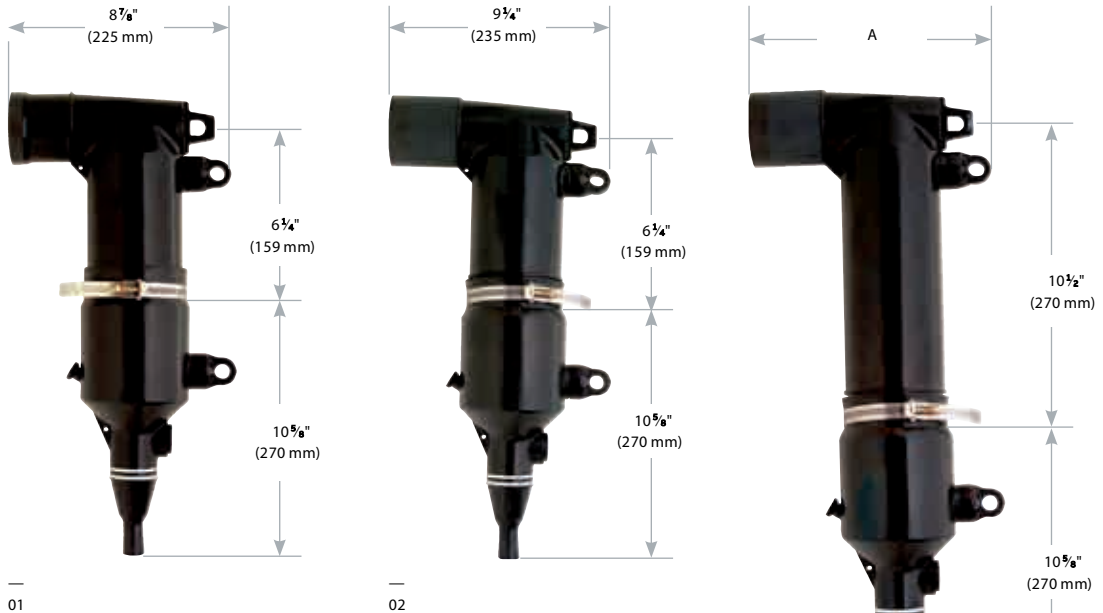

Note: 1. All dimensions rounded up to the nearest eighth inch.  
 2. Also available with direct test port.  
 3. Dimensions with direct test port units are 10 3/4" (260 mm) or 10 5/8" (270 mm).  
 4. 168FLR3 uses a large housing with a 15 kV, 200 A elbow interface.

03

## Current-limiting fuse ordering information

The following diagram shows how to construct a catalog number for full-range current-limiting fuses.

Indicates field that must be filled in to complete order.

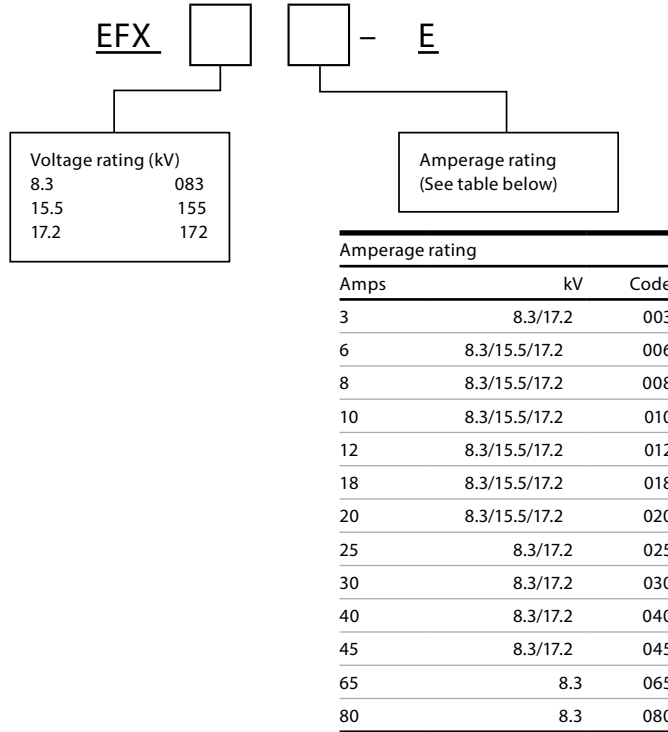

- 01 8.3 kV (3–45 A)/15.5 kV (6–20 A) fuse
- 02 8.3 kV (65–80 A)/17.2 kV (3–45 A) fuse

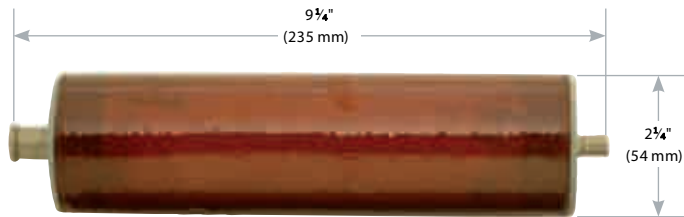

01

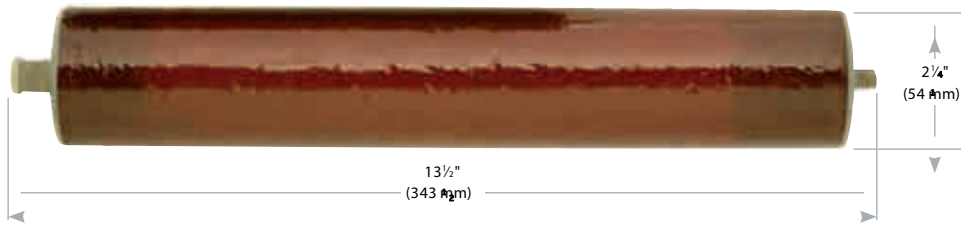

02

Note: All dimensions rounded up to the nearest eighth inch.

## Shielded surge arresters Metal oxide varistor (MOV) surge arresters

Fully shielded, fully submersible for convenient energized connection with 200 A loadbreak or deadbreak components up to 35 kV.

- IEEE 386 interfaces provide convenient energized connection with other 200 A loadbreak or deadbreak components
- EPDM molded rubber construction – Fully shielded and fully submersible for a variety of applications
- Compact size enables installation in your existing cabinetry, saving you money
- Three styles of arresters available fit your application and are easy to install
- Direct connection on PSA and BSA versions eliminates the need for additional accessories, saving even more money
- #4 AWG ground lead tethered to the jacket withstands 10,000 A for 10 cycles without fusing
- Ground lead also controls end plug when ejected, preventing uncontrolled trajectory, and maintains the housing shield ground connection after failure

Voltage surges that exceed the BIL rating of the distribution system components will cause damage to the installed equipment. To protect against these surges, overhead surge arresters are widely used. Their application is understood since overhead lines and equipment are directly affected by voltage surges (e.g. lightning). However, the use of overhead arresters alone will not guarantee proper protection of the insulation in the underground portion of an electrical distribution system. The let-through surge from the riser pole arresters into the underground systems could be enough to cause damage to the aging equipment insulation.

Elastimold<sup>®</sup> MOV surge arresters provide high voltage lightning and switching surge protection of transformers, cable, equipment and other components typically located on underground power distribution systems. Proper placement, voltage selection and coordination with riser pole arresters minimize damaging surge voltages by improving protective margins.

Typical applications include installing an arrester at the end of a radial system or at both ends of an open point on a loop system. Additional arresters can be added at strategic locations upstream from the end point for optimum protection.

Metal oxide varistor (MOV) surge arresters are available in three styles: elbow (ESA<sup>™</sup>), parking stand (PSA<sup>™</sup>) and bushing (BSA<sup>™</sup>). The PSA and BSA arresters permit direct connection, eliminating the need for additional accessories. ESA elbow arresters are also available with a 200 A deadbreak interface for mating with other deadbreak accessories.

The following highlights the different installation options using bushing and parking stand arresters where elbow arresters are normally used. Using BSAs and PSAs will contribute to saving space inside transformers and improving operability.

### Ratings

High current, short duration	All MOV arresters withstand two discharges of 40 kA crest
Low current, long duration	All MOV arresters withstand 20 surges of 75 A/2,000 microseconds duration
Duty cycle test	All MOV arresters withstand 22 operations of 5 kA crest at 8 x 20 microseconds duration while energized at rated voltage for the initial 20 operations and at maximum continuous operating voltage (MCOV) for the final two operations

Following each of the preceding tests, MOV arresters demonstrate thermal recovery at MCOV.

Installation options

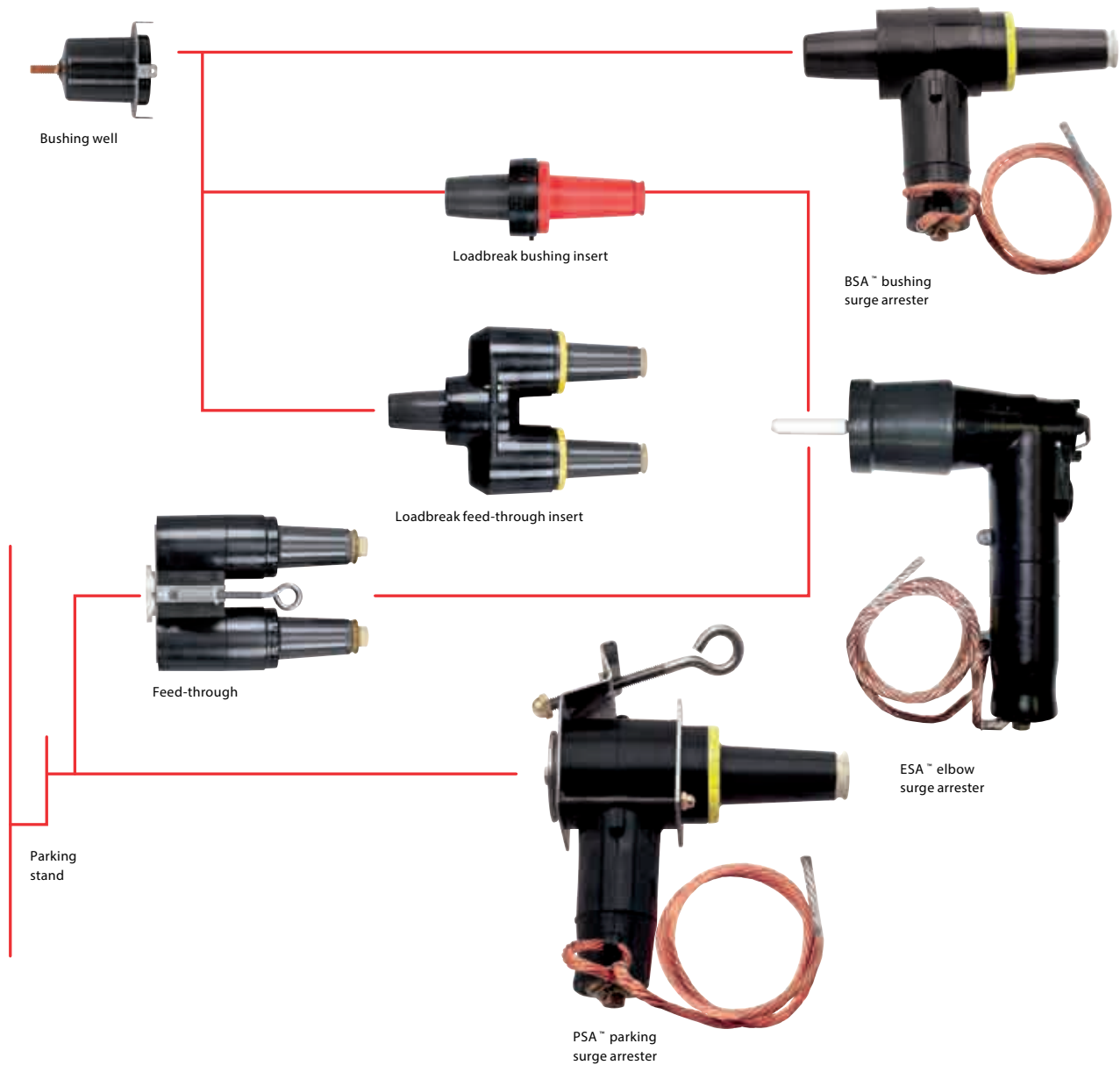

## Shielded surge arresters

### Loop-feed circuit (type 2 transformer)



Two elbow arresters and a feed-through  
This approach uses elbow arresters only. (One of the elbow arresters may be mounted on the H1A bushing if operating procedures permit.)



Elbow arrester and parking stand arrester  
This approach can reduce overcrowding by eliminating the feed-through device. This is desirable in a mini-pad transformer.



Bushing arrester and parking stand arrester\*  
This approach is best for increasing operability and reducing transformer overcrowding.

The bushing arrester enables the source cable to be positioned on H1A, which conforms with some operating practices.

A bushing arrester mounted on H1A can be directed downward without interference. Potential interference between an elbow arrester on H1B and a cable parked on P is eliminated.

The bushing arrester requires significantly less space than an elbow arrester used with a feed-through insert.

Operability is enhanced because the open point can be closed by moving the parked cable to H1B without removing an arrester.

\* Transformers must be specified with bushing wells.

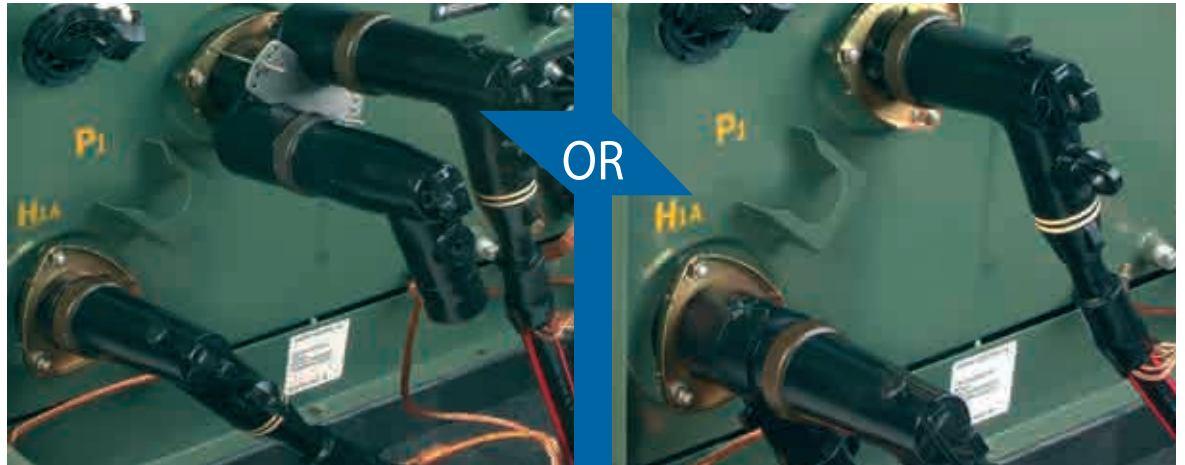

#### Additional margin of protection

An additional margin of protection may be gained by adding an arrester at the next transformer upstream on each side of the open point. This application is dependent on the system voltage and condition of the cable.

If an additional arrester is added in the circuit, it can be an elbow arrester in combination with a feed-through insert or it can be a bushing arrester. Use of a bushing arrester will reduce transformer faceplate overcrowding.

#### Other configurations

Other configurations are possible, such as specifying a bushing arrester on every transformer. This enables the open point to be quickly and easily moved to any point in the circuit while maintaining the surge protection (without moving all of the portable surge arresters).

The externally mounted bushing arrester provides the surge protection benefits without the negative factors of an under-oil arrester.

Shielded surge arresters  
Radial-feed circuit (end point)



Single-bushing transformer  
To add surge protection to a single-bushing transformer, use a bushing arrester or an elbow arrester with a feed-through insert.



Two-bushing transformer  
To add surge protection to a two-bushing transformer at the end point of a radial-feed circuit, add an elbow arrester to the unoccupied bushing or use a bushing arrester.



Conversion of a radial-feed transformer to a loop-feed, open-point transformer  
 To convert a single-bushing transformer to a loop-feed, open-point transformer, add a parking stand arrester and an elbow arrester in combination with a feed-through insert.

—  
 Protective characteristics

Voltage class (kV)	MCOV (kV RMS)	Duty cycle rating (kV RMS)	Maximum discharge voltage (kV crest) 8 x 20 microsecond current wave				
			1.5 kA	3 kA	5 kA	10 kA	20 kA
15	2.55	3	8.06	8.48	8.74	9.36	10.4
	5.1	6	16.12	16.95	17.47	18.72	20.8
	8.4	10	28.21	29.66	30.57	32.76	36.4
	10.2	12	32.24	33.9	34.94	37.44	41.6
	12.7	15	40.3	42.38	43.68	46.8	52
	15.3	18	48.36	50.85	52.41	56.16	62.4
25	8.4	10	28.21	29.66	30.57	32.76	36.4
	10.2	12	32.24	33.9	34.94	37.44	41.6
	12.7	15	40.3	42.38	43.68	46.8	52
	15.3	18	48.36	50.85	52.41	56.16	62.4
	17	21	56.42	59.32	61.14	65.52	72.8
38	19.5	24	64.48	67.8	69.88	74.88	83.2
	22	27	72.54	76.28	78.62	84.24	93.6
	24.4	30	80.6	84.75	87.35	93.6	104
	29	36	96.72	101.7	104.82	112.32	124.8
	32.5	40.5	109.35	114.98	118.5	126.97	141.07



## Shielded surge arresters

### To specify and order an MOV surge arrester:

1. Determine the appropriate maximum continuous operating voltage (MCOV) for your system voltage using the arrester application table below.
2. Specify the appropriate Elastimold \* catalog number from the selection chart.

Arrester application table

Voltage class (kV)	System line-to-line voltage kV RMS		MCOV* kV RMS	
	Nominal	Maximum	Solidly grounded neutral circuits	3-Wire ungrounded circuits
15	2.40	2.54	2.55	2.55
	4.16	4.40	2.55	5.10
	4.80	5.08	5.10	5.10
	6.90	7.26	5.10	8.40
	8.32	8.80	5.10	8.40
	12.47	13.20	8.40	15.30
	13.20	13.97	8.40	15.30
	13.80	14.50	8.40**	15.30
	13.80	14.50	10.20	15.30
25	6.90	7.26	5.10	8.40
	8.32	8.80	5.10	8.40
	12.47	13.20	8.40	15.30
	13.20	13.97	8.40	15.30
	13.80	14.50	8.40**	15.30
	13.80	14.50	10.20	15.30
	20.78	22.00	12.70	-
	20.78	22.00	15.30**	-
	23.00	24.34	15.30	-
	24.94	26.40	15.30	-
	24.94	26.40	17.00**	-
28.00	29.80	17.00	-	

\* MCOV = maximum continuous operating voltage.

\*\* Preferred arrester MCOV for this system voltage.

## Selection chart

	Description	Voltage class (kV)	Cat. no.	MCOV kV RMS
	200 A BSA bushing surge arrester (includes assembly tool)  See notes 1-4	15	167BSA-3	2.55
			167BSA-6	5.10
			167BSA-10	8.40
			167BSA-12	10.20
			167BSA-15	12.70
		25	167BSA-18	15.30
			273BSA-10	8.40
			273BSA-12	10.20
			273BSA-15	12.70
			273BSA-18	15.30
	200 A ESA elbow surge arrester  See notes 1, 2, 5	15	167ESA-3	2.55
			167ESA-6	5.10
			167ESA-10	8.40
			167ESA-12	10.20
			167ESA-15	12.70
		25	167ESA-18	15.30
			273ESA-10	8.40
			273ESA-12	10.20
			273ESA-15	12.70
			273ESA-18	15.30
	200 A PSA parking stand arrester  See notes 1-3	15	167PSA-3	2.55
			167PSA-6	5.10
			167PSA-10	8.40
			167PSA-12	10.20
			167PSA-15	12.70
		25	167PSA-18	15.30
			273PSA-10	8.40
			273PSA-12	10.20
			273PSA-15	12.70
			273PSA-18	15.30
	600 A ESA elbow surge arrester	15/28	K655ESA-10	8.4
			K655ESA-12	10.2
			K655ESA-15	12.7
			K655ESA-18	15.3
			K655ESA-21	17.0

Note: 1. Elastimold PSA and BSA arresters are equipped with a fully rated 200 A switching and fault-close loadbreak bushing.

2. Elastimold arresters use high strength, silver epoxy-bonded MOV blocks and shunted spring connections for the best circuit connection.

3. A 36" #4 AWG ground lead is provided with each unit.

4. BSA installed by turning internal hex bolt (accessed through the 200 A bushing interface) with a

$\frac{5}{16}$ " hex wrench and bent-wire torque wrench supplied with each unit.

5. For 15 kV and 25 kV class deadbreak system elbow arresters, use catalog number 156ESA with the appropriate duty cycle rating.

## Shielded surge arresters

To specify and order an MOV surge arrester:

1. Determine the appropriate maximum continuous operating voltage (MCOV) for your system voltage using the arrester application table below.
2. Specify the appropriate Elastimold \* catalog number from the selection chart.

Arrester application table

Voltage class (kV)	System line-to-line voltage kV RMS		MCOV* kV RMS	
	Nominal	Maximum	Solidly grounded neutral circuits	3-Wire ungrounded circuits
35	23.00	24.34	-	22.00
	34.50	36.51	22.00**	-
	34.50	36.51	24.40	29.00

\* MCOV = maximum continuous operating voltage.

\*\* Preferred arrester MCOV for this system voltage.

Selection chart

	Description	Voltage class (kV)	Cat. no.	MCOV kV RMS
	200 A BSA bushing surge arrester  See notes 1-4	35	375BSA-24	19.50
			375BSA-27	22.00
			375BSA-30	24.40
	200 A ESA elbow surge arrester  See notes 2-3	35	375ESA-24	19.50
			375ESA-27	22.00
			375ESA-30	24.40
			375ESA-36	29.00
	200 A PSA parking stand arrester  See notes 1-3	35	375PSA-24	19.50
			375PSA-27	22.00
			375PSA-30	24.40
	600 A ESA elbow surge arrester	35	755ESA-18	15.3
			755ESA-24	19.5
			755ESA-27	22.0
			755ESA-30	24.4
			755ESA-33	26.8
			755ESA-36	29.0
755ESA-40.5	32.5			

- Note: 1. Elastimold PSA and BSA arresters are equipped with a fully rated 200 A switching and fault-close loadbreak bushing.  
 2. Elastimold arresters use high strength, silver epoxy-bonded MOV blocks and shunted spring connections for the best circuit connection.  
 3. A 36" #4 AWG ground lead is provided with each unit.  
 4. BSA installed by turning internal hex bolt (accessed through the 200 A bushing interface) with a  $\frac{5}{16}$ " hex wrench and bent-wire torque wrench supplied with each unit.  
 5. For 15 kV and 25 kV class deadbreak system elbow arresters, use catalog number 156ESA with the appropriate duty cycle rating.

# Underground

We offer a complete package of underground cable accessories — everything you need to connect, ground, splice, terminate and protect underground cable from 5kV to 138kV — along with solid dielectric switchgear in compact, modular designs that fit easily into tight vaults.



- 1 Fisher Pierce<sup>®</sup> test point faulted circuit indicator and voltage indicator
- 2 Elastimold PCJ power cable joint
- 3 Hi-Tech<sup>™</sup> backup current-limiting fuse
- 4 Elastimold SFJ Shrink-Fit<sup>™</sup> joint
- 5 Elastimold 200 A loadbreak bushing and insert
- 6 Elastimold 200 A and 600 A surge arresters
- 7 Elastimold 600 A deadbreak spiking tee and grounding aid device
- 8 Elastimold advanced connection system - 600 A deadbreak elbow separable connectors and Combot
- 9 Elastimold 200 A grounding elbow
- 10 Elastimold Tru-Break<sup>™</sup> switchgear module
- 11 Elastimold pad-mount switchgear
- 12 Elastimold small vault switchgear
- 13 Elastimold 200 A loadbreak and deadbreak elbows
- 14 Homac<sup>™</sup> transformer connectors
- 15 Homac Flood-Seal<sup>™</sup> splices
- 16 Homac Flood-Seal breakaway street light kit



Whatsapp | 999 251 9322  
Teléfono fijo | 999 98 5996  
Ventas | [ventas@taacsa.com](mailto:ventas@taacsa.com)  
Soporte Técnico | [soporte.comercial@taacsa.com](mailto:soporte.comercial@taacsa.com)

[f](#) [@](#) [in](#) [▶](#)  
[taacsa.com](http://taacsa.com)